



TRUE EUROPE

UK OFFICE: Field's End Road, Goldthorpe, Nr. Rotherham, South Yorkshire S63 9EU, UK  
 Tel +44 01709 888 080 • Fax +44 01709 880 838 • Free Phone 0 800 783 2049  
 Free Phone to U.S. 0 800 894 928 • EU OFFICE: Hauptstr. 269 • 79650 Schopfheim • Germany  
 Tel +49 07622 6883 0 • Fax +49 07622 6883 499 • www.truemfg.com



8/16

Model:  
**TUC-48D-2-HC**

**Undercounter:**  
*Drawered Refrigerator with Hydrocarbon Refrigerant*



### TUC-48D-2-HC

- ▶ True's undercounter units are designed with enduring quality that protects your long term investment.
- ▶ Designed using the highest quality materials and components to provide the user with colder product temperatures, lower utility costs, exceptional food safety and the best value in today's food service marketplace.
- ▶ Factory engineered, self-contained, capillary tube system using environmentally friendly R290 hydrocarbon refrigerant that has zero (0) ozone depletion potential (ODP), & three (3) global warming potential (GWP).
- ▶ Oversized, environmentally friendly forced-air refrigeration system holds 33°F to 38°F (.5°C to 3.3°C).
- ▶ All stainless steel front, top and ends. Matching aluminum finished back.
- ▶ Interior - attractive, NSF approved, clear coated aluminum liner with stainless steel floor.
- ▶ Each drawer accommodates one (1) full size 12"L x 18"W x 6"D (305 mm x 458 mm x 153 mm) food storage box or one ½ size and one ½ size pan (sold separately).
- ▶ Heavy duty PVC coated wire shelves.
- ▶ Foamed-in-place using a high density, polyurethane insulation that has zero ozone depletion potential (ODP) and zero global warming potential (GWP).

ENERGIA - ENERGIJA - ENERGETIKA  
 ENERGIJA - ENERGY - ENERGIE  
 ENERGI

**548**  
 kWh/annum

**169 L**

**4**  
 30°C-55%

2015/1094

### PLAN VIEW

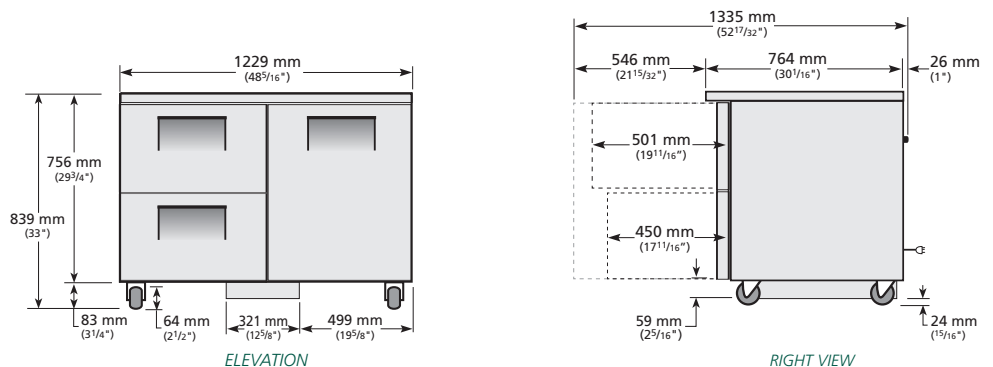

### ROUGH-IN DATA

Specifications subject to change without notice.  
 Chart dimensions rounded up to the next whole millimeter (inches rounded up to the next 1/8").

Model	Model Type	Doors	Drawers	Shelves	Cabinet Dimensions (mm)			Net Volume (litres)	EEC	EEI	24 hr/ Energy Consumption (kWh)	Annual Energy Consumption (kWh)	Crated Weight (kg)
					L	D	H						
TUC-48D-2-HC	Counter Chilled	1	2	2	1229	766	839	169	A	24.7	1.501	548	139

† Depth does not include 1" for rear bumpers.