



Project _____

Item # _____

Quantity _____

Snack System

Models: SNACK-1, -2

The Hatco®/Suntec Snack System will help expand your menu and your sales. With a single or dual electric baker, you can easily switch the replaceable plates to serve breakfast items, lunch foods and a variety of snacks in between. Freshly bake as many or few items as you need, resulting in no waste at the end of the day. Add more variety to your menu in small quantities and increase sales according to the season, time of day and location.

Standard features

- Adjustable time/temperature controls enable operators to cook continuous, consistent quality products
- Exclusive heating elements provide exceptional heat distribution throughout the entire cooking plate, ensuring even cooking of each product
- Four programmable preset buttons for each cooking cycle. A cooking cycle consists of three different settings:
 - Temperature
 - Time
 - Top Cooking Plate Power
- One-touch release with latch opener for easy plate replacement
- Removable/Interchangeable plates are easily cleaned with warm, soapy water
- Compact design is suitable for any location and stainless steel frame provides durability and easy cleaning
- Comes with a cleaning brush, standard Round Belgian Waffle Plates and an additional set of plates of your choosing



Accessories

- Nylon Brush
- Interchangeable Plates - comes with Belgian and one other plate of your choosing -
 - Freestyle
 - Belgian
 - Coffee Bean
 - Sandwich
 - Panini
 - Donut
 - Chelky

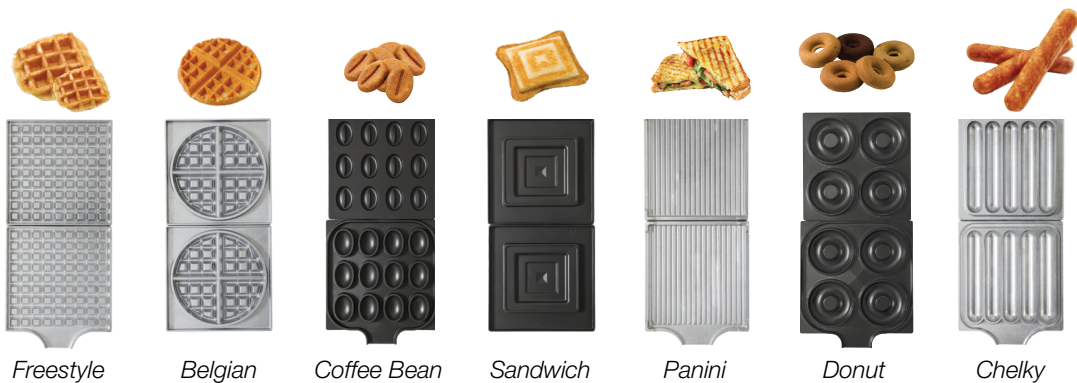

For operation, location and safety information, please refer to the Installation and Operating Manual.



HATCO CORPORATION | P.O. Box 340500 Milwaukee, WI 53234-0500 U.S.A. | (414) 671-6350

www.hatcocorp.com | support@hatcocorp.com | [Find a Hatco Rep](#) | [Image Library](#) | [Document Library](#) | [Patents](#) | [Chat](#)



Waffle Makers

Models: Snack-1, -2

SNACK-1

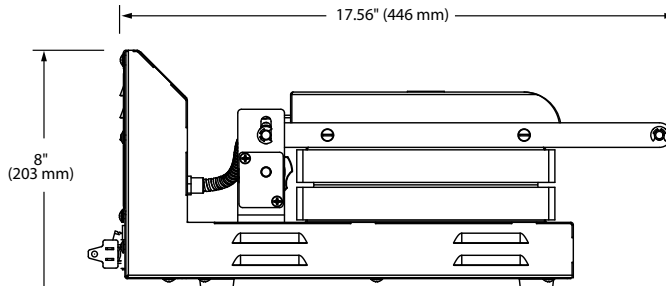
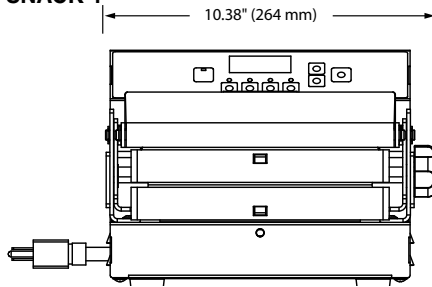

SNACK-2

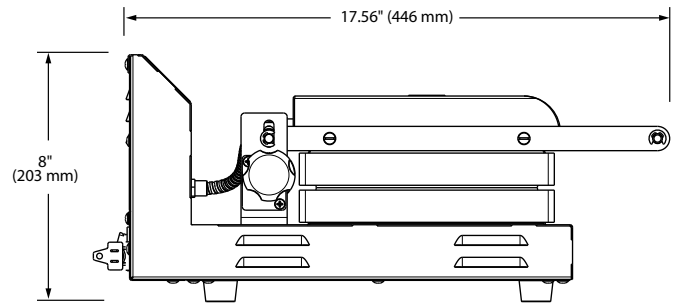
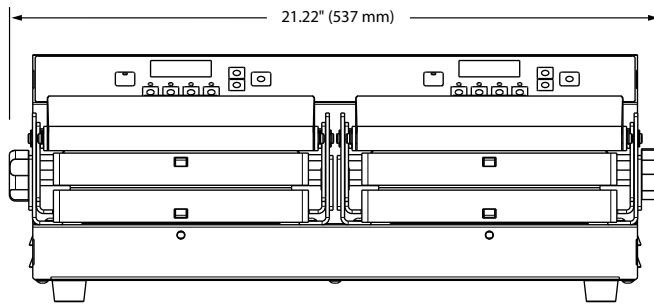

FRONT VIEW

SIDE VIEW

SPECIFICATIONS Snack System

The shaded areas contain electrical information for International models

Model	Description	Dimensions (W x D x H)	Voltage	Watts	Amps	Plug	Approx. Ship Weight
SNACK-1	Single unit	10.38" x 17.56" x 8" (264 x 446 x 203 mm)	120	900	7.5	NEMA 5-15P	23 lbs. (11 kg)
			100	740	7.4	PSE	
			220-230-240 (CE)	823-900-980	3.7-3.9-4.0	BS-1363, Schuko 7/7, AS-3112, CH1-10P	
			220/60	823	3.7	BS-1363	
SNACK-2	Double unit	21.22" x 17.56" x 8" (537 x 446 x 203 mm)	120	1800	15.0	NEMA 5-15P*	42 lbs. (19 kg)
			100	1480	14.8	PSE	
			220-230-240 (CE)	1647-1800-1960	7.5-7.8-8.2	BS-1363, Schuko 7/7, AS-3112, CH1-10P	
			220/60	1646	7.4	BS-1363	

* Canadian models use NEMA 5-20P.

CORD LOCATION

Back of unit bottom left-hand side.

PLUG CONFIGURATIONS

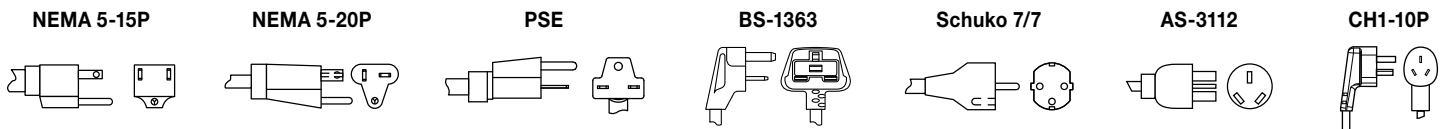

PRODUCT SPECS

Snack System

The Snack System shall be Model ... as distributed for the Hatco Corporation, Milwaukee, WI 53234 U.S.A.

The Snack System shall be rated at ... watts, ... volts, and be ... inches (millimeters) in overall width.

It shall consist of easy-to-clean stainless steel frame and removable/interchangeable aluminum cooking plates. The Snack System features a Power I/O (on/off) switch

on the back, a multi-function control panel and a top plate adjustable knob. All units are equipped with a factory attached 6' (1829 mm) power cord and plug.

Accessories include a cleaning bursh and additional cooking plates: Freestyle, Belgian, Coffee Bean, Sandwich, Panini, Donut and Chelky.

Warranty consists of 24/7 parts and service assistance (US and Canada only).

HATCO CORPORATION

P.O. Box 340500 Milwaukee, WI 53234-0500 U.S.A. | (414) 671-6350



www.hatcocorp.com

support@hatcocorp.com

[Find a Hatco Rep](#)

[Image Library](#)

[Document Library](#)

[Patents](#)

[Chat](#)