



# VACUUM SEALER SE-204

Tabletop model. 4 m<sup>3</sup>/h. 280 mm.



## FEATURES AND BENEFITS

- ✓ Powered by Busch.
- ✓ Vacuum controlled by sensor.
- ✓ Vacuum PLUS.
- ✓ Digital keyboard.
- ✓ Control panel equipped with display indicating the exact vacuum percentage.
- ✓ "Pause" button to marinate food.
- ✓ Safe liquid packing thanks to sensor control.
- ✓ Double seal.
- ✓ Cordless sealing bar.
- ✓ Bag-sealing programme.
- ✓ Pulse-controlled decompression.
- ✓ Vac-Norm ready with Automatic decompression.
- ✓ Stainless steel body and chamber. Deep-drawn chamber.
- ✓ Damped transparent lid of highly durable polycarbonate.
- ✓ Dry-oil programme for drying the pump.
- ✓ Working hours counter for oil changes.
- ✓ Safety system with protection against vacuum failure.
- ✓ NSF-listed model.

## SALES DESCRIPTION

280 mm. sealing bar.

4 m<sup>3</sup>/h Busch vacuum pump.

Vacuum controlled by sensor.

## INCLUDES

- ✓ Sensor Controls
- ✓ Up to 10 seconds of extra vacuum pull
- ✓ Soft air function
- ✓ Dry oil cycle
- ✓ BUSCH pump
- ✓ NSF Approved
- ✓ Clear methacrylate lid
- ✓ Filling plate



[www.sammic.co.uk](http://www.sammic.co.uk)

Food Service Equipment Manufacturer

Unit 2, Trevanah Road  
Troon Industrial Park  
LE4 9LS - Leicester

[uksales@sammic.com](mailto:uksales@sammic.com)  
Tel.: +44 0116 246 1900



Project	Date
Item	Qty
Approved	

FOOD PRESERVATION AND SOUS-VIDE  
VACUUM PACKING MACHINES - "SENSOR" LINE

product sheet  
updated 06/03/2018



# VACUUM SEALER SE-204

Tabletop model. 4 m<sup>3</sup>/h. 280 mm.



## SPECIFICATIONS

Pump capacity: 4 m<sup>3</sup>/h

Bar length: 280 mm

Total loading: 100 W

Vacuum pressure (maximum): 2 mbar

### Internal dimensions

✓ Width: 288 mm

✓ Depth: 333 mm

✓ Height: 110 mm

### External dimensions (WxDxH)

✓ Width: 337 mm

✓ Depth: 431 mm

✓ Height: 307 mm

Net weight: 23 Kg

Noise level (1m.): -- dB(A)

Background noise: 32 dB(A)

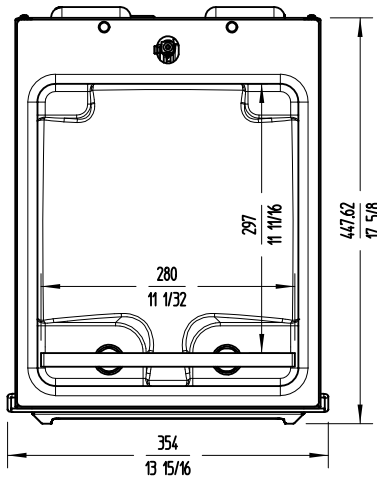
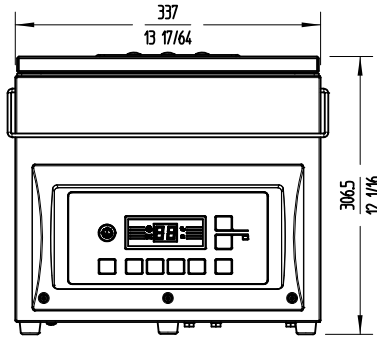

## AVAILABLE MODELS

1140620 Vacuum packing machine SE-204 230/50-60/1

\* Ask for special versions availability

## ACCESSORIES

- Filling plates
- Vac-norm external vacuum kits
- Vac-norm containers
- Smooth bags for vacuum packing

FOOD PRESERVATION AND SOUS-VIDE  
VACUUM PACKING MACHINES - "SENSOR" LINE



[www.sammic.co.uk](http://www.sammic.co.uk)

Food Service Equipment Manufacturer

Unit 2, Trevanah Road  
Troon Industrial Park  
LE4 9LS - Leicester

[uksales@sammic.com](mailto:uksales@sammic.com)  
Tel.: +44 0116 246 1900



Project

Date

Item

Qty

Approved

product sheet  
updated 06/03/2018