

Prodigy® Nugget Ice Machines up to 365 kg



Features

- AutoAlert™ indicator lights for better visibility.
- Operational footprint among the industry's smallest.
- Industry-exclusive QR code instantly connects users to service information and warranty history.
- Front-located air filter for more efficient operation.
- Self-aligning front panel for easy access to key components.
- Patented WaterSense purge control automatically reduces scale buildup.
- Smart-Board™ advanced feature module available for additional diagnostic capabilities.
- Optional Vari-Smart™ ice level control allows operators to customize ice levels.
- Antimicrobial protection guards internal surfaces between cleanings.
- A full range of water- and energy-saving features.

Matching Bins

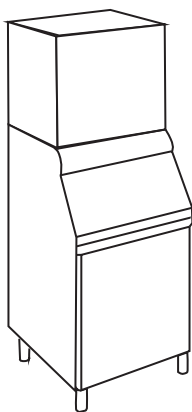

SB 393
SB 530

Other options available

Technologies



		21°C : 10°C	32°C : 21°C
		[kg] [lb]	[kg] [lb]
N 0922 A		365 805	288 635



[V/Hz/ph]
220-240/50/1



R404A

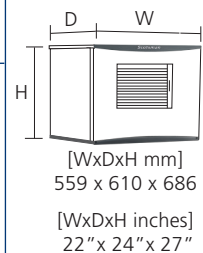

This product qualifies for the following listings:



Nugget Ice1 g
Residual water content 8%
16x15x7-8 mm

By far the dryest and hardest form of Flake ice, it is produced at just below zero degrees Celsius just like all other flake ice forms, but it is then compressed to remove excess residual water, reducing it to as low as 10% of its original volume.

2 Years Warranty

Subject to certain limitations and exclusions

Certified ISO 9001

www.scotsman-ice.it
www.scotsman-ice.com

Other models in this range:
N 0622

Prodigy® Nugget Ice Machines up to 365 kg

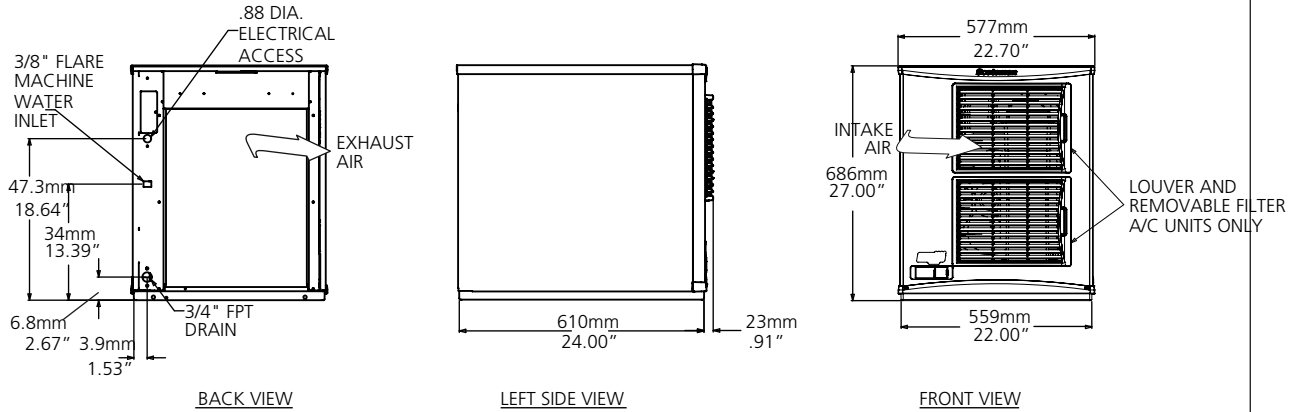

Minimum		Maximum
10°C (50°F)		40°C (100°F)
5°C (40°F)		40°C (100°F)
-10%		+10%
1,4 bar 20 psi		5,5 bar 80 psi

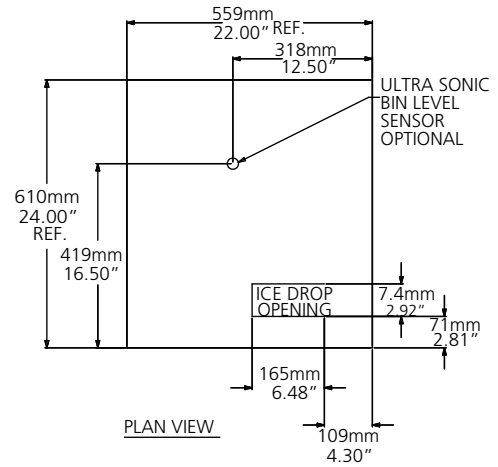

	+C° -C°	[Btu/h] [W]	[W]	FUSE	[kWh] - 100 kg	[l/h]	32°C 90°F 21°C 70°F	[kg] [lb]
N 0922 A		7600 2220	1300	15 A	4,7	12,0	3,2	95 210

IMPORTANT NOTICE:
Models and specifications are subject to change without notice.
This spec sheet is meant for commercial purpose only.
For technical documentation please refer to our service manuals.

www.scotsman-ice.it
www.scotsman-ice.com

Scotsman®
Ice Systems

Milano Madrid Chicago Dubai Singapore Shanghai Johannesburg