

Fish Cabinet X3



Suitable For
Fresh Fish

Features and Benefits

- Fully automatic
- Low speed fan for even cooling
- Adjustable feet
- Digital controller and temperature display
- Drain for cleaning
- Replaceable door gasket
- Self closing door
- 5 Removable drawers with stainless steel perforated risers
- Holds approximatley 10-12 stone of fresh fish
- Must be used in conjunction with crushed ice
- Reversible Door - Factory Option

Technical Specifications

Temperature Range	-2/0°C
Refrigerant	R404a
Type of Defrost	Timed Off Cycle
Exterior Finish	Stainless Steel
Interior Finish	Stainless Steel
Power Required	13 Amp
Max Ambient	30°C at 55% RH
Climate Class	4

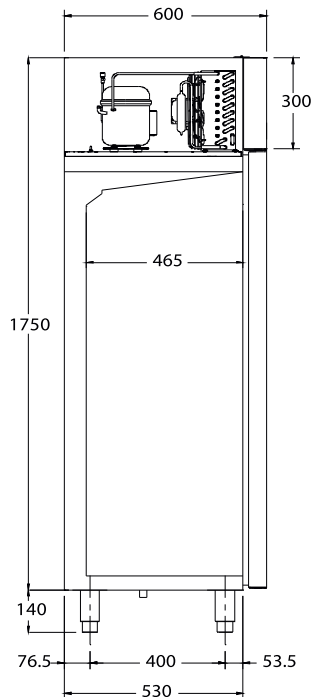

Model	Description	Dimensions (mm)			Kg	Gross Int. Volume	Net Useable Vol.	kWh/Annum	No. of Shelves	Price	Energy Rating	Next Day	
		Ext. H	W	D									
X3	Stainless Steel	Ext.	1890	600	600	104	311ltr (11 cu.ft)	260ltr	978	5 trays	£1,554	F	✓
		Int.	1340	500	465								