

# Service manual

## COMPACT 220/320/420

Item number: 765042425

Release date:

Released by: JABP

Revision date:

Revision no.: 0000

Gram Commercial (CVR-nr. 41423986)

Aage Grams Vej 1

6500 Vojens, Denmark



# Content

Scope of this service manual.....	3
Introduction to this manual.....	3
Intended use.....	4
Safety information.....	4
Location.....	5
Optimizing the energy consumption.....	7
General description.....	8
Refrigerant / GWP.....	8
Climate / temperature class.....	9
Electrical connection.....	9
General use.....	10
Operating the product.....	11
Keylock.....	12
Adjusting the cabinet temperature.....	12
Setting temperature alarm parameters.....	13
Temperature alarms.....	14
Messages and alarms shown in the display.....	15
Defrosting.....	15
Defrost water.....	16
Reversing the door.....	16
Light – glass door.....	17
Cleaning.....	17
Door gaskets.....	17
Long term storage.....	18
Service.....	18
Disposal.....	18
Entering/adjusting factory default parameter settings.....	19
Parameters and default settings.....	20
Test of inputs / outputs.....	23
How to physically access the controller.....	24
How to boot the correct software on a spare part controller.....	25
How to change the controller.....	25
Controller layout and description.....	26
Reversing the glassdoor.....	27
EC-Declaration of conformity.....	28
Wiring diagram – K 220/320/420.....	29
Wiring diagram – KG 220/320/420.....	30
Wiring diagram – F 220/320/420.....	31
Wiring diagram – FG 220.....	32
Piping diagram.....	33

## Scope of this service manual

This service manual is made in order to aid service technicians when servicing and troubleshooting on the Gram Compact product range, and in particular related to the electrical controller (GCC).

The service manual is **not intended to be handed to end-users**, since unintended changes of settings potentially can cause situations where the temperature inside the cabinet cannot be kept as intended, (high foodstuff temperatures can occur if wrong adjustments are made).

Another side effect of making unintended changes of the controller settings, is potentially causing damage to the refrigeration system.

***Changing service level parameter settings to differ from the factory default, will void the warranty!***

This service manual does explain how to access the different additional controller levels related to service. These levels are:

- Entering / adjusting factory default parameter settings (adjustable if necessary)
- Entering and using the I/O test area
- How to boot the correct software on a spare part controller
- How to change the controller and what to take care of while doing so

Furthermore, this manual does explain:

- The layout of the controller and the different connections including the specifications of these.
- EC declaration of conformity
- Wiring diagrams for:
  - K – Models (Refrigerators with solid door)
  - F – Models (Freezers with solid door)
  - KG/FG – Models (Refrigerators and freezers with glass door)

## Introduction to this manual

This manual will advise you how to service the product.

Changes in installation and other use of the product than described under intended use, might affect the operation and durability of the product.

The manual is written according to our current technical knowledge. We constantly work on updating this information, and we reserve the right to make technical changes.

# User manual

## Intended use

The product is intended for the storage of foodstuffs in non-household environments but not for the display to or access by customers.

The product is designed for storage at a constant temperature and is not to be used for chilling down or freezing hot/fresh foodstuff.

The product is only to be used for the purpose for which it has been expressly designed. Any other use could cause that the foodstuff stored in the product is not kept at the correct temperature or even cause damage to the product.

The product is not suited for storing blood plasma, laboratory samples, pharmaceuticals or similar substances.

The manufacturer will not be held liable or responsible for any damage caused by improper, incorrect or unreasonable use of the product.

## Safety information

### **Important**

Description of symbols used in this manual.



**Warning** Lacking observation to these instructions might result in accidents with personal injury.



**Important** If these instructions are not observed, the product might be damaged or destroyed.

Be aware that Gram Commercial has taken precautions to ensure that the safety of the product is in order.

### ***Please read carefully the following information regarding safety.***



It is important, that everyone who are to use or install the product, to have access to this manual.



This appliance is not intended for use by persons with reduced physical, sensory or mental capabilities, or lack of experience and knowledge, unless they have been given supervision or instruction concerning use of the appliance by a person responsible for their safety.



Children should be supervised to ensure that they do not play with the appliance.



The appliance might contain parts with sharp edges in the compressor compartment, and in the inside compartment.



The appliance is not to be transported on a sack truck, there is a danger of losing the balance, causing danger to persons.



Do not pull the power cord to disconnect the appliance, or when moving the appliance.

## Location

When receiving the product, check the packaging material for damage.

If any damage occurs at the packaging material, it should be considered if the product might have been damaged too. If the damage is substantial, please contact your dealer.

How to remove the transport pallet:

### COMPACT 220 with skids/small wheels:

The cabinet can be lifted off the pallet (see Fig.1).

### COMPACT 220/320/420 with castors or legs:

The cabinet is tilted slightly backward, and the front part of the pallet can be removed.

Then the cabinet is tilted slightly forward, and the rear part can be removed. (see Fig.2)



This task requires at least 2 persons.

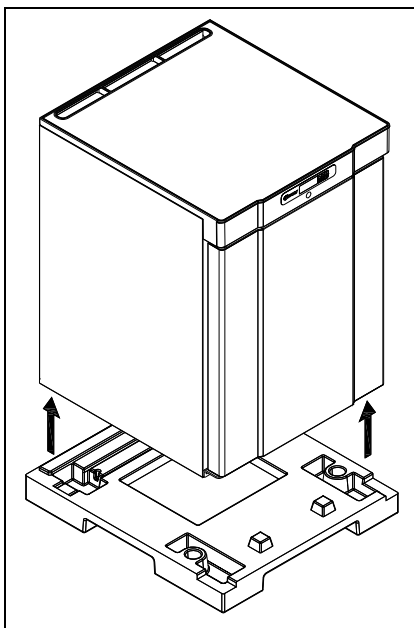

Fig.1

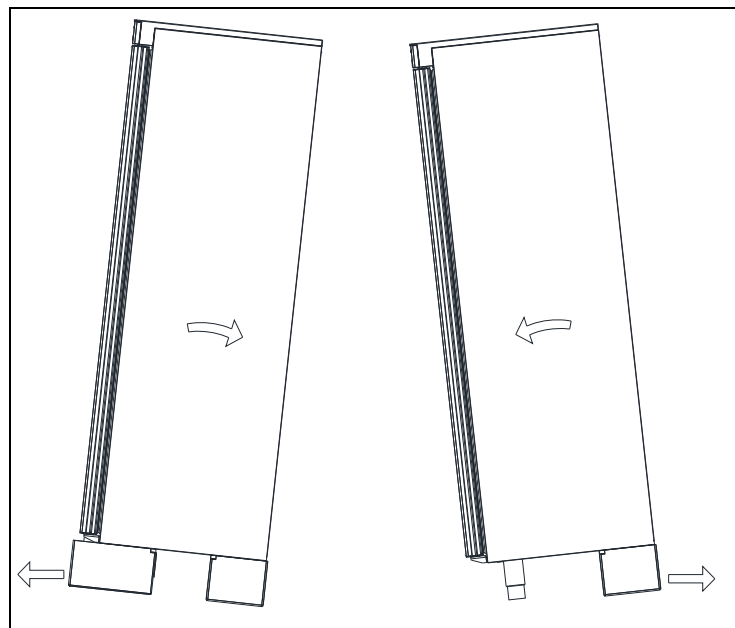

Fig. 2



If the cabinet has been transported in horizontal position it must stand upright at least 2 hours before it is started to allow the oil from the compressor to run back.



Because of the heavy weight of the product, the floor might be damaged or scratched when moving the product.



Correct set up gives the most effective operation.

The product should be located in a dry and adequately ventilated room.



To ensure efficient operation, it may not be placed in direct sunlight or against heat-emitting surfaces. The product is designed to operate in an ambient temperature between +16°C and +30°C.



Avoid placement of the product in a chlorine/acid-containing environment (swimming bath etc.) due to risk of corrosion.



Parts of the product is equipped with a protecting film, which should be removed before use.



Clean the product with a mild soap solution before use.

The set-up place must be level and horizontal.

For versions with legs, use the adjustable legs to make sure that the product stands level and upright, see Fig.3.

For versions with castors, the locking devices of the two front castors must be activated, when the product is in place, see Fig.3. The base must be level, and the product may not be placed on frames or the like.

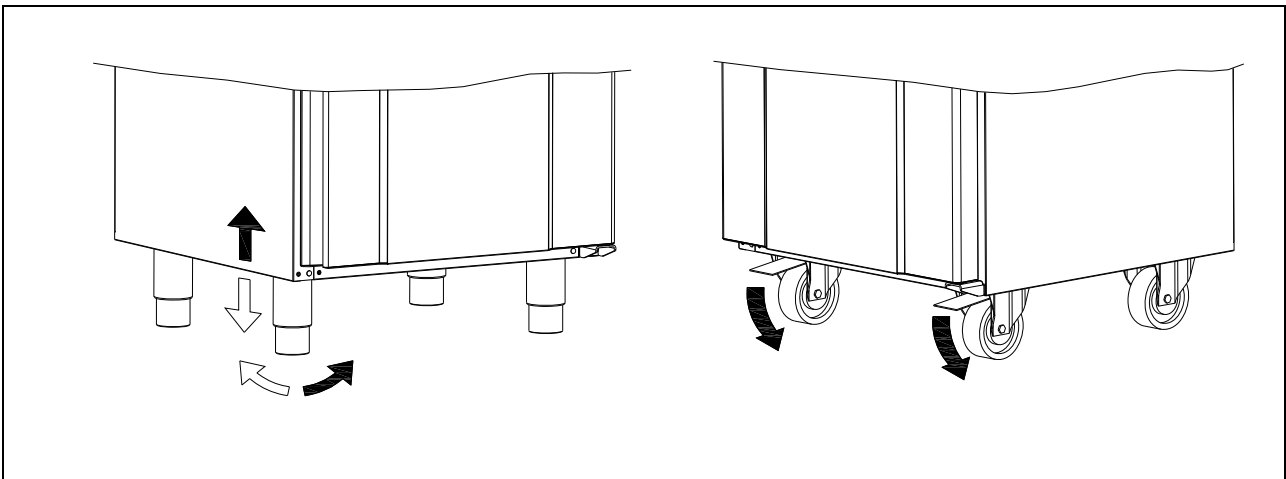

Fig. 3

Cabinets equipped with a glass door, must be fastened to a stable surface to ensure the cabinet does not tilt, when the door is open. Brackets for fastening are supplied with the cabinet (fasteners not supplied, use fasteners according to wall material/type).

See how to mount brackets in Fig.4

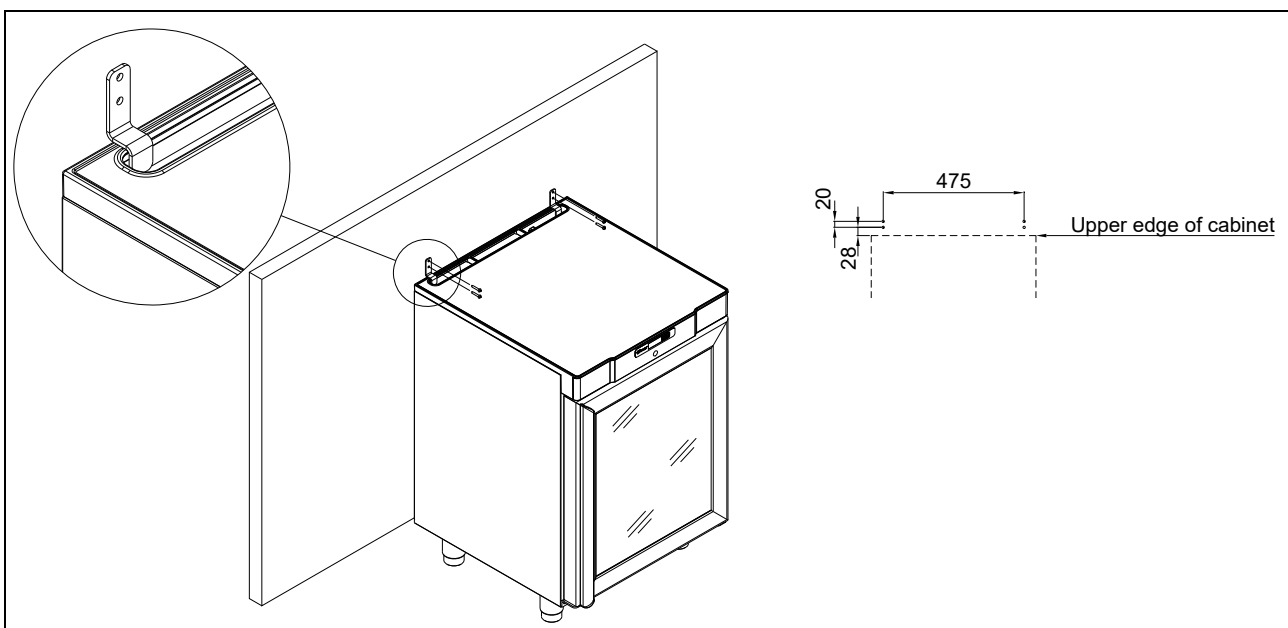

Fig. 4



To ensure that users, surroundings and stored items are not injured/damaged if the cabinets tilts, these brackets must be mounted.

The cabinet can be installed freestanding, against a wall or COMPACT 220 can be built under a worktop.

The cabinet must have sufficient ventilation and free air circulation beneath, above and behind the cabinet. There must be a minimum clearance of 30 mm above the cabinet, and 20 mm at the sides.

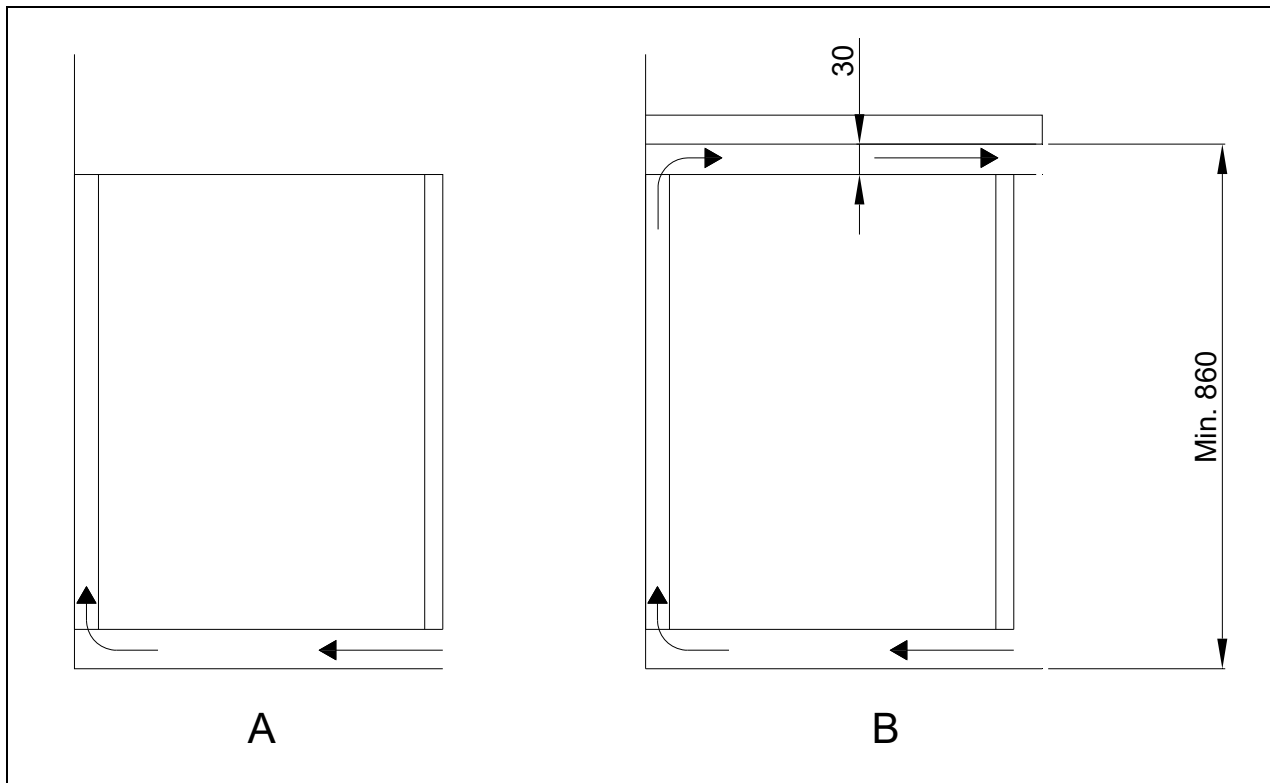

Fig. 5

## Optimizing the energy consumption

- Correct set up gives the most effective operation.
- The product should be located in a dry and adequately ventilated room.
- To ensure efficient operation, it may not be placed in direct sunlight or against heat-emitting surfaces. The product is designed to operate in an ambient temperature between +16°C and +30°C.
- Do not keep the door open for too long.
- Do not set the temperature setpoint too low.
- The product should be placed as close as possible up against the wall.

## General description

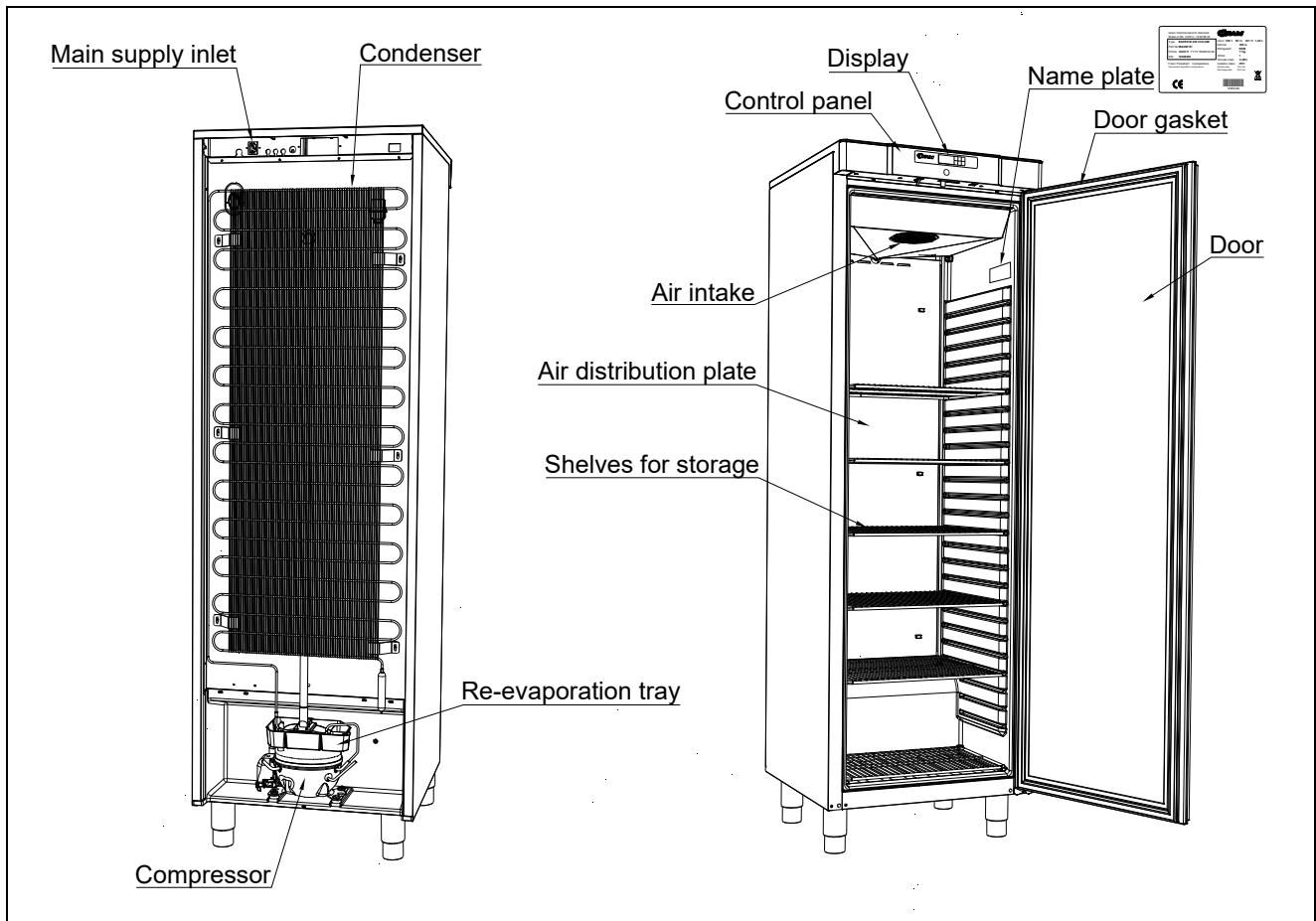

Fig. 6



## Refrigerant / GWP

Refrigerators	Refrigerant	Charge kg	GWP	CO <sub>2</sub> equivalent
COMPACT K 220	R600a	0,033	3	0,10
COMPACT KG 220	R600a	0,031	3	0,09
COMPACT K 320	R600a	0,043	3	0,13
COMPACT KG 320	R600a	0,043	3	0,13
COMPACT K 420	R600a	0,045	3	0,14
COMPACT KG 420	R600a	0,045	3	0,14
<b>Freezers</b>				
COMPACT F 220	R600a	0,029	3	0,10
COMPACT FG 220	R600a	0,029	3	0,10
COMPACT F 320	R600a	0,035	3	0,11
COMPACT F 420	R600a	0,060	3	0,18

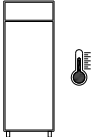

## Climate / temperature class

Products are tested according to the following climate and temperature classes. Information about the product's climate and temperature class can be found at the name plate (see fig.12)

Climate class		Temperature class	
3	25°C / 60 % RH	L1	-18°C
4	30°C / 55 % RH	M1	+5°C

## Electrical connection

Read the text below thoroughly before electrical connection.



The product is intended for connection to alternating current. The connection voltage (V) and frequency (Hz) are shown on the name plate in the cabinet (see Fig.6). Only the supplied cord is to be used.



Never use an extension cord for this appliance!  
If a wall socket is placed in a longer distance than the length of the supplied power cord, contact an electrician to establish a wall socket within the range of the supplied power cord.



If the product is defective, it must be examined by a properly skilled technician with proper knowledge of the product during the warranty period.

Outside the warranty period, it is advisable to use the service advised by your dealer. If this is not the case, assistance is required from a properly skilled technician with proper knowledge of the product.

Always disconnect the power if interruptions in power supply occur, and when electrical parts are removed/put on, and before cleaning and maintenance of the product.

Repairing of electrical/technical parts may only be performed by properly skilled technicians with proper knowledge of the product.

Do not use the product before all coverings are installed, so that live or rotating machine parts cannot be touched.

The product is not to be used outdoor.

All earthing requirements stipulated by the local electricity authorities must be observed. The plug and wall socket should then give correct earthing. If necessary, contact an electrician.



Make sure the product is switched off at the socket before service is performed on electrical parts. It is not sufficient to switch off the product by the START/STOP key as there will still be voltage to some electrical parts of the product.

Always disconnect the power if interruptions in power supply occur, and when electrical parts are removed/put on, and before cleaning and maintenance of the product.

Repairing of electrical/technical parts may only be performed by properly skilled technicians with proper knowledge of the product.

Do not use the product before all coverings are installed, so that live or rotating machine parts cannot be touched.

The product is not to be used outdoor.

All earthing requirements stipulated by the local electricity authorities must be observed. The plug and wall socket should then give correct earthing. If necessary, contact an electrician.



Make sure the product is switched off at the socket before service is performed on electrical parts. It is not sufficient to switch off the product by the START/STOP key as there will still be voltage to some electrical parts of the product.

## General use



Do not damage the refrigeration system parts.



During normal operation, some parts of the refrigeration system in the compressor compartment might reach high temperatures and could therefore cause burns if touching these components.



Do not use electrical devices inside the product.



To ensure correct and efficient air flow in the cabinet, the shaded areas must be kept free of items.



All items to be stored, that are not wrapped or packed, must be covered in order to avoid unnecessary corrosion of the inner parts of the cabinet.



If any controller parameters are changed from default, this could cause that the product is not functioning normally, and harmful temperatures could damage items that are kept inside the product.



If the product is turned off, wait minimum 3 minutes before turning it on again. This is to protect the compressor from damage



Maximum loading of wire shelf: 40 kg



Do not store explosive substances such as aerosol cans with flammable propellant in this appliance.

Be aware, if bottles are stored near the air outlet, they may freeze up and break, causing a risk of injury (only K and KG products).

Do not overpack the product with foods. Allow some space between them to ensure a good airflow.

Moist or fresh foods and those with a strong smell should be wrapped up in a plastic film or packed in a container. Otherwise the food may dry out or give their smell to other foods.

Foods containing acetic acid or yeast should be wrapped up in plastic film. Otherwise they may accelerate corrosion of the evaporator and metal parts, resulting in failure.



To ensure correct and efficient air flow in the product, the shaded areas and the area above the top load line must be kept free of items. (see Fig. 7)

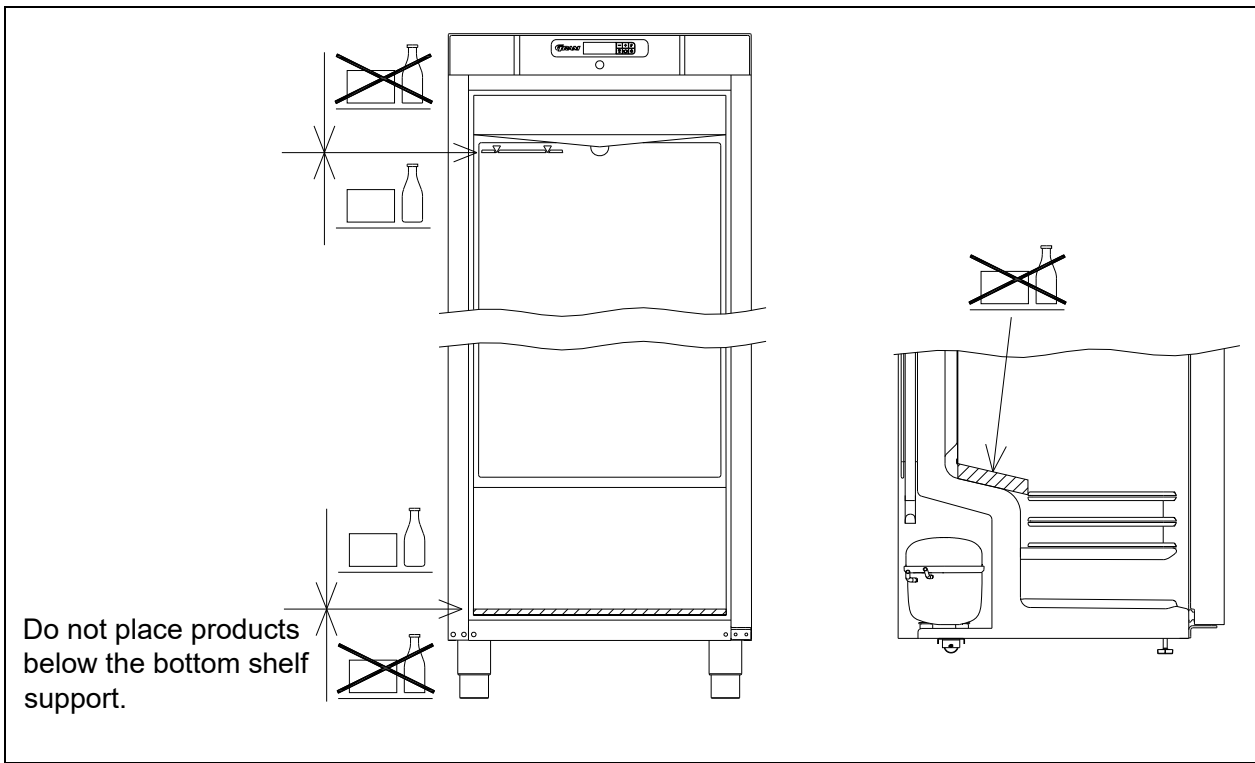
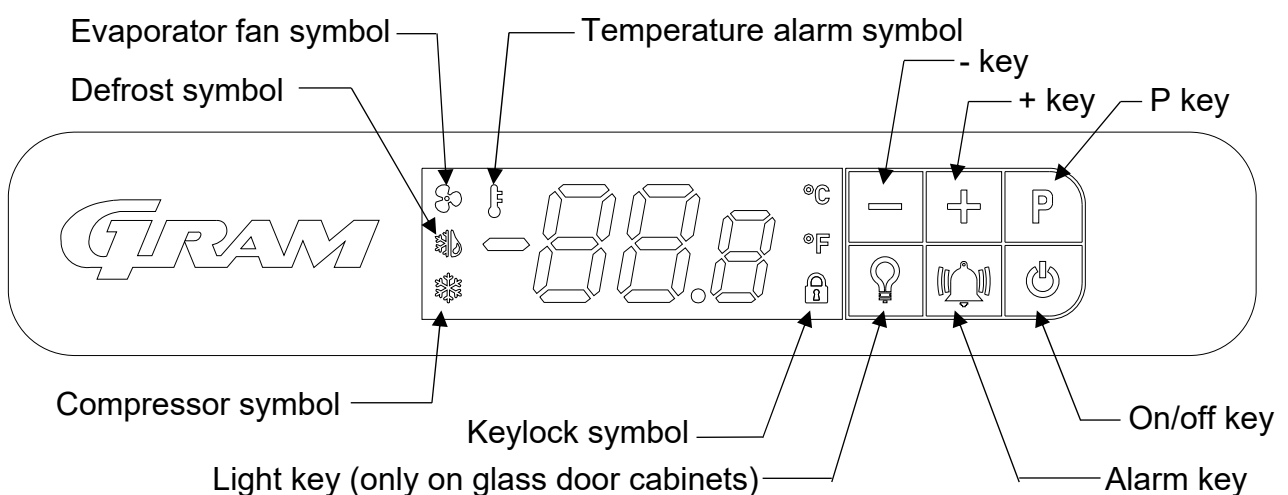



Fig. 7

## Operating the product

### Display overview



If the cabinet is not turned on when connecting it to the main power source, the following must be done:

To turn the cabinet on, push and hold the  key for 5 seconds.

During a short boot sequence, all light segments in the display are lit. After that the controller does start up in normal operation mode.

This does mean that the refrigeration system will work to reach and maintain the factory adjusted default set temperature:

For refrigerators (K and KG-models) this set point is 5°C (adjustable from 2 to 12°C)  
For freezers (F and FG-models) this set point is -18°C (adjustable from -10 to -22°C)

The cabinet is turned off likewise, by pushing and holding the  key for 5 seconds.

### Control lights

The following control lights are located on the display:



Compressor symbol. This LED is on while the compressor is running. Flashes during temperature setting.



Defrost symbol. This LED is lit constantly during the defrosting cycle.



Evaporator fan symbol. This LED is turned on while the evaporator fan is running.



Temperature alarm symbol. This LED is turned on if a temperature alarm occurs. See chapter on temperature alarms.

## Keylock

A condition for any adjustments to the controller settings whatsoever, is making sure that the controller keys are not locked. When powering up the controller the keys will automatically be locked after two minutes.

This is done to prevent unintended changes of settings due to cleaning and daily use. Furthermore, it is done in order to minimize the risk of unauthorized tampering with the controller.

When the display keys are locked the keylock symbol is lit.



### To unlock the keys:

Push and hold any key for 5 seconds to unlock the controller keys. During this period of unlocking, the keylock symbol flashes simultaneously with the display flashing **UnL**. When the controller has been successfully unlocked, the keylock symbol turns off, and the display reverts to normal operation.

### To lock the keys:

Leaving the controller without touching any key for two minutes, will result in the keylock being activated automatically. The change from being unlocked to being locked is shown by flashing the keylock symbol simultaneously with the display flashing **Loc** for the last 5 seconds. After that the keylock symbol is lit and the keys are locked. The display does reverts to normal operation.

## Adjusting the cabinet temperature

To change the set temperature, push  once,  flashes, and the current set point is shown in the display, with one decimal place after the comma.

Push  $\oplus$  or  $\ominus$  to change the temperature set point. The new set point temperature is confirmed/saved by pushing **P** once. The display returns to normal operation.

To exit without change push  once, or do not touch any key for 60 seconds

After power failure the controller returns to stored settings.

## Setting temperature alarm parameters

Adapting the below parameters to suit the real conditions of use, it is important to ensure that the settings do not make the alarm system either too sensitive or too insensible.

Adjusting the difference between temperature set point and **hAL** / **LAL** alarm settings to narrow, will result in unintended alarms. A narrow gap combined with a too short **dAh** could result in an **AH** alarm, just by opening the door.

**dAh** should never be adjusted to less than 30 minutes.

To access the temperature alarm parameters, push and hold  and **P** simultaneously for 5 seconds. The display will flash the first temperature alarm parameter **hAL**.

To access the individual parameters push **P**.

To move between and adjust the parameters use  $\oplus$  and  $\ominus$ .

Push **P** to store the new setting. The controller automatically jumps to the next parameter.

Adjustable parameters are:

Factory default

<b>hAL</b>	High Alarm Limit	+ 25° C
<b>LAL</b>	Low Alarm Limit	- 29° C
<b>dAh</b>	Time delay Alarm high	120 minutes
<b>dAL</b>	Time delay Alarm Low	20 minutes
<b>Atd</b>	Alarm temperature differential	2K

The above parameter settings will result in the following:

To trigger a high temperature alarm (**Ah**) the cabinet temperature must be above **hAL** = 25°C for

more than **dAh** = 120 minutes. This will result in  being lit and the display alternating between **Ah** and the present cabinet temperature.

Once the temperature goes below 23°C (**hAL** – **Atd**) the alarm changes from present to being

logged. The display will show current temperature and  will remain lit indicating there has been a temperature alarm.

To trigger a Low temperature alarm (**AL**) the cabinet temperature must be below **LAL** = -29°C for

more than **dAL** = 20 minutes. This will result in  being lit and the display alternating between **AL** and the present cabinet temperature.

Once the temperature goes above -27°C (**LAL** + **Atd**) the alarm changes from present to being

logged. The display will show current temperature and  will remain lit indicating there has been a temperature alarm.



## Temperature alarms

The following temperature alarms can be displayed:

**Ah** Alarm high temperature

**AL** Alarm Low temperature

If an alarm occur, **Ah** or **AL** will be shown alternating with the current temperature.

If the temperature gets back within the accepted limits, the current temperature will be shown in the display and  will remain lit until the alarm has been reset. After 3 days  will be turned off, but the alarm will still be kept in the alarm log.

### Displaying alarms:



The temperature alarm log stores information related to the latest 10 temperature alarms (named A 1 to A10). If a new alarm occurs the oldest alarm (A10) will be erased.

Push  once to open the log.

- If there is no present or logged temperature alarm the display will show “no” flashing for 4 seconds. After that the controller will revert to normal operation.
- If there are present or logged temperature alarms the display will show the most recent temperature alarm being:

A 0	Present / ongoing temperature alarm.
A 1.. A10	Not present temperature alarms logged

Once the cabinet temperature, related to a present temperature alarm (A 0), is no longer outside the alarm ranges, this A 0 alarm becomes the new A 1. Etc.

Use  and  to navigate between the different alarms.

Push  to open a temperature alarm in order to show:

### Example 1 – alarm A 0: (Present temperature alarm)

Ah Indicating it is a high temperature alarm (AL indicating a low temperature alarm)  
8.0 the maximum temperature in °C during the alarm (If AL the minimum temperature)

dur alarm duration until now

01h the alarm has been ongoing for 1 hour

15' .... and 15 minutes

### Example 2 – alarm A1 to A10: (alarms in the log – not present)

Ah Indicating it is a high temperature alarm (AL indicating a low temperature alarm)  
9.0 the maximum temperature in °C during the alarm (If AL the minimum temperature)

dur alarm duration

01h the alarm lasted for 1 hour

15' .... and 15 minutes



tSE time since the end of the alarm

08h the alarm ended 8 hours ago (maximum 99 hours)

Each value is displayed alternately for approx. 1 second.

It is not possible to reset or delete a present temperature alarm A 0

## Resetting alarm symbol

Look through all non-present alarms, after each alarm Push  to verify having seen the alarm. To exit an alarm without verifying, push . Once all alarms have been verified,  will turn off, unless there is a present alarm.

Push , to leave alarm log.

### Deleting alarms:

Push  once to open the log.

Display shows A 1. Delete all non-present temperature alarms by holding  for 5 seconds. Once the alarm log is deleted the display flashes " - - - " for 3 seconds.

## Messages and alarms shown in the display

- OP**      **OP** shown constantly, indicates door open. If alternating with temperature, door has been open for more than 2 minutes. Close the door and **OP** will disappear.
- E1**      **E1** indicates defective room sensor. Monitor temperature until replaced.  
**Request service assistance immediately.**
- E2**      Alternating between **E2** and temperature indicates defective evaporator sensor. Defrosting will be time-based. (freezer) **Request service assistance.**
- Ah**      Alarm high temperature – See explanation under temperature alarms
- AL**      Alarm Low temperature – See explanation under temperature alarms

## Defrosting

### COMPACT K/KG:

Defrosting is automatically performed 4 times every 24 hours.  is lit.

### COMPACT F/FG:

Defrosting is automatically performed 4 times every 24 hours.  is lit.

### Manual defrosting:

If operating with frequent door opening and replenishment, manual defrosting can be necessary. Manual defrosting is started by holding  for 5 seconds.



Do not use sharp or pointed objects to accelerate the defrosting process.

## Defrost water

The cabinet produces water during defrosting, which is led into a tray in the compressor compartment (see Fig.6). A re-evaporation pipe from the refrigeration system, placed in the tray, re-evaporates the water



It is recommended to clean the tray and water trap when necessary - at least once a year. Remember to disconnect the cabinet before cleaning. Be careful not to damage the re-evaporation pipe during cleaning.

## Reversing the door



Always disconnect the power supply prior to starting the reversing of the door.

The door can be changed from righthand-hinged to lefthand-hinged, or vice versa.

To do so, proceed as follows:

### Models with solid door:

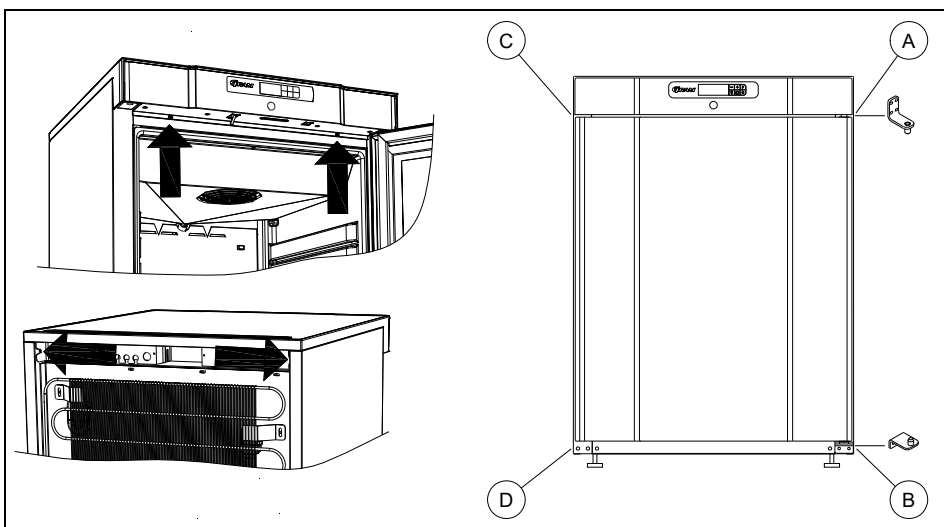

Fig. 8

1. Switch off the power at the mains socket.
2. Open the door
3. Dismantle the two screws that hold the control panel at the front and loosen the two screws the hold the tabletop in the back, pull the complete tabletop a little forward, and then tilt it upwards.
4. Dismantle the hinge in pos. A, and lift off the door.
5. Dismantle the hinge in pos. B, and mount it in pos. D.
6. Turn the door 180°, and fit it to the hinge in pos. D.
7. Mount the hinge from pos. A in pos. C, and move the bracket from pos. C to pos. A.
8. Re-position and fasten the tabletop.
9. Apply power to the cabinet again.



### Models with glass door:

The door should only be reversed by a properly skilled service technician with knowledge of the product.

## Light – glass door

The light in the glass door, can be switched to work in two different ways.

Light constantly on (Lco) or light off when door closed (Ldo).

Push and hold  for 5 seconds to change between Lco and Ldo.

## Cleaning

Insufficient cleaning will cause that the product will not work at optimum performance, or eventually it will be defective.



Before cleaning, the product should always be disconnected.



Do not flush the product with water, do not use water jet or steam hose as this may cause short-circuits in the electrical system.



Cleansing agents containing chlorine or compounds of chlorine as well as other corrosive means, **are not to be used**, as they might cause corrosion to the cabinet and the evaporator.



The compressor compartment and in particular the condenser must be kept free from dust and dirt. This is best done with a vacuum cleaner and a brush.



For the external maintenance and cleaning – Use a hot soapy damp cloth. After cleaning rinse off with a moist cloth only containing water. Finalize the cleaning by wiping the cabinet dry, using a dry cloth. Cabinets with stainless steel exterior, should be treated with stainless steel polish at the end.



The product should be cleaned internally with a mild soap solution at suitable intervals and checked thoroughly before it is put into operation again.

## Door gaskets

This chapter deals with the importance of a well-functioning door gasket.

Gaskets are an important part of a refrigerator/freezer. Gaskets with reduced functionality, reduces the tightness of the cabinet. Reduced tightness might cause increased humidity, internal icing, an iced-up evaporator (leading to reduced refrigeration capacity), and in worst case reduced lifecycle of the cabinet.

Therefore it is important to be aware of the condition of the gasket. Regular inspection is recommended.

The gasket should be cleaned regularly with a mild soap solution.

If a gasket needs replacement, contact your supplier.

## Long term storage

If the product is taken out of operation, and need to be prepared for long-term storage, clean the inside compartment, the door and door gasket thoroughly with a hot soapy damp cloth. Eventual remnants of food do create mold.

It is advisable to leave the cabinet door open during long term storage, in order to minimize the risk of bad smell and the building of mold inside the cabinet.

## Service

The refrigerating system and the hermetically sealed compressor require no maintenance - they merely must be kept clean.

If refrigeration fails, first investigate whether the unit has been unintentionally disconnected or switched off at the socket, or whether a fuse has blown.

If it is not possible to find the cause of the refrigeration failure, please contact your dealer.

When reporting a malfunction please state the type and the 8-digit serial number (S/N) of the cabinet. This information is found on the name plate, see Fig. 6.

## Disposal

Electrical and electronic equipment (EEE) contains materials, components and substances that can be dangerous and harmful to human health and the environment if the waste (WEEE) is not disposed of properly.

Products that are labelled with a “crossed-out wheelee bin” is considered electric and electronic equipment. The crossed-out wheelee bin symbolizes that waste of this type cannot be disposed of with unsorted municipal waste but must be collected separately.

Contact your local dealer when the product needs to be disposed of.

Please be aware of not damaging the refrigeration system and piping when a product is taken out of use. This will prevent the uncontrolled escape of the refrigerant from the refrigeration system.

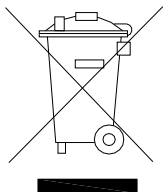

# Service manual

## Entering/adjusting factory default parameter settings

This part of the manual **should not** be handed to anyone outside the Gram/Hoshizaki organisation, unless it is necessary.

Prior to entering the controller for whatever reason, it is important to make sure that the controller keys are not locked. When powering up the controller the keys will automatically be locked after two minutes.

This is done to prevent unintended changes of settings due to cleaning and daily use. Furthermore, it is done in order to minimize the risk of unauthorized tampering with the controller.

When the display keys are locked the keylock symbol is lit.

### To unlock the keys:

Push and hold any key for 5 seconds to unlock the controller keys. During this period of unlocking, the keylock symbol flashes simultaneously with the display flashing **UnL**. When the controller has been successfully unlocked, the keylock symbol turns off, and the display reverts to normal operation.

The below list of parameters is divided into different groups, each representing a dedicated area of the operation cycle. These groups are:

- S = System configurations
- C = Compressor control related parameters
- D = Defrost related parameters
- F = Evaporator fan related parameters
- A = Alarm related parameters

Under each section there are numerous sub-parameters which can be adjusted.

In order to access the list of parameters and settings, the following must be done:

- Press and hold **P** and **⏻** simultaneously for 10 sec.
- The first setting group "S" will be shown in the display.
- Use **←** and **→** to navigate between the different setting groups.
- Press **P** to access the chosen setting group.
- Use **←** and **→** to navigate between the different setting names.
- Press **P** to access the chosen setting name.
- Use **←** and **→** to change the settings.
- Press **P** to save the new setting and the display will revert to the setting name.
- Press **⏻** to move back one level.

## Parameters and default settings

Relation	Setting Group	Setting name	Parameter name	Unit	Range	Adjustment resolution	Default K	Default KG	Default F	Default FG
SYSTEM	<b>S</b>									
SYSTEM		S1	Default setpoint	°	S2 to S3	0,1	5	5	-18	-18
SYSTEM		S2	Minimum limit for SP setting	°	-30 to S3	1	2	2	-22	-22
SYSTEM		S3	Maximum limit for SP setting	°	S2 to 20	1	12	12	-10	-10
SYSTEM		S4	Celsius grade decimal shown on display 0= No, 1=yes	NUMERIC	0 or 1	N/A	0	0	0	0
SYSTEM		S5	Evaporator probe 0= absent, 1= present	NUMERIC	0 or 1	N/A	0	0	1	1
SYSTEM		S6	display update delay (Temperature)	SEC	0 to 300	10	10	10	10	10
SYSTEM		S7	Temperature fluctuation filter <sup>1</sup>	K	0 to 3	0,5	3	3	3	3
SYSTEM		S8	Offset room sensor	K	-5 to +5	0,1	0,0	0,0	0,0	0,0
COMP	<b>C</b>									
COMP		C1	Comp. Cut-in above SP	K	1 to 5	0,1	1,5	1,5	1,5	1,5
COMP		C2	Comp Cut-out below SP	K	1 to 5	0,1	1,5	1,5	1,5	1,5
COMP		C3	Comp. On delay at power up	Min	0 to 10	1	2	2	2	2
COMP		C4	Minimum comp. Off time	Min	0 to 30	1	5	5	5	5
COMP		C5	Minimum comp. On time	Min	0 to 30	1	3	3	3	3
COMP		C6	On comp. with defective P1 (room sensor)	Min	0 to 30	1	5	5	10	15
COMP		C7	Off comp. with defective P1 (room sensor)	Min	0 to 30	1	15	10	10	5
COMP		C8	Compressor off delay when Id1 activated	Min	0 to 10	1	5	5	2	2

<sup>1</sup> This means if the temp. detected by the room sensor is within  $SP \pm S7$ , the display will show SP. When the temperature detected by the room sensor does go above/below  $SP \pm S7$ . The actual temperature will be displayed. When the temperature does return to being within  $SP \pm S7$ , the displayed temperature will be actual until SP is reached. When SP is reached the temperature fluctuation filter will be re-activated.

Relation	Setting Group	Setting name	Parameter name	Unit	Range	Adjustment resolution	Default K	Default KG	Default F	Default FG
DEF	<b>d</b>									
DEF		d1	Defrosting interval	Hours	4, 6, 8 or 12	-	6	6	6	6
DEF		d2	Defrost type 1= FAN, 2=ELEC, 3=Automatic (see d11) 4= HOTGAS	NUMERIC	1, 2, 3 or 4	N/A	1	1	2	2
DEF		d3	Defrost reference 0= time, 1=combined time and room sensor, 2= combined time and evap. temperature., 3= combined time and Id1 activation, 4 = evap. Temp	NUMERIC	1 or 2	N/A	1	1	2	2
DEF		d4	Dripping duration	Min	0 to 5	1	0	0	2	2
DEF		d5	Defrost end temp. (P2 sensor)	°	0 to 12	1	N/A	N/A	10	10
DEF		d6	Defrost duration time max.	Min	0 to 60	1	30	30	30	30
DEF		d10	Defrost end temp differential above SP, measured on Room sensor (P1) if F0 = 0 and S5 = 0 Actual P1 temperature ≥ SP + d10 = defrost end (only if d2 =1 and d3 = 1)	K	0 to 5	1	2	2	N/A	N/A
DEF		d12	Display reed out during defrosting 0 = Actual room temperature 1 = - d - 2 = dEF 3 = If room temperature is below SP + C1 at time of defrost start, SP is displayed. If room temperature is above SP + C1 at time of defrost start, actual temp at defrost start is displayed.	NUMERIC	0, 1, 2 or 3	N/A	3	3	3	3
DEF		d13	Delay in display temp update after end defrost if d12 = 3	Min	0 to 60	5	15	15	30	30
DEF		d14	Time < d14 since Id1 activation to skip defrosting cycle (only if d2 = 1 and d3 = 3)	Min	0 to 180	10	30	30	N/A	N/A
DEF		d15	Maximum number of consecutive skipped defrosts	NUMERIC	0 to 5	1	2	2	N/A	N/A

Relation	Setting Group	Setting name	Parameter name	Unit	Range	Adjustment resolution	Default K	Default KG	Default F	Default FG
FAN	<b>F</b>									
FAN		F0	Fan activity during normal operation (compressor on) 0 = Switched on 1 = Switched on with compressor on, related to F2, F3, F4, F5, F6	NUMERIC	0 to 1	N/A	1	1	1	1
FAN		F1	Fan on-delay after defrosting	Min	0 to 10	1	3	3	0	0
FAN		F2	Evap. temperature before fan start	°	-10 to 0	1	N/A	N/A	-1	-1
FAN		F3	Fan pause time during compressor off	SEC	0 to 600	5	300	300	300	300
FAN		F4	Fan pulse time during compressor off	SEC	15 to 300	5	60	60	60	60
FAN		F5	Fan off delay time after compressor off	SEC	15 to 300	5	60	60	60	60
FAN		F6	Fan on time after door closing with compressor off 0 = Running F4 setting More than 0 = settings in sec.	SEC	0 to 300	5	0	0	0	0
FAN		F7	Fan activity during defrost and drip time 0 = Fan on 1 = Fan off (restart after defrosting see F2)	NUMERIC	0 to 1	1	0	0	1	1









Relation	Setting Group	Setting name	Parameter name	Unit	Range	Adjustment resolution	Default K	Default KG	Default F	Default FG
ALARM	<b>A</b>									
ALARM		HAL	High Alarm Limit	°	+25 to -35	1	25	25	25	25
ALARM		LAL	Low Alarm Limit	°	-35 to 25	1	-35	-35	-35	-35
ALARM		dAH	Time delay Alarm High	Min	5 to 240	1	120	120	120	120
ALARM		dAL	Time delay Alarm Low	Min	5 to 240	1	20	20	20	20
ALARM		Atd	Alarm temperature differential	K	0 to 10	1	2	2	2	2
ALARM		OP	Open door alarm delay	Min	1 to 10	1	2	2	2	2

## Test of inputs / outputs

In order to ease the trouble shooting for the field engineer, the different inputs and outputs can be forced on and off manually. Doing so makes it possible to force an output on, in order to measure if the different components are powered. The reason could e.g. be if the compressor is not running.

**NB:** Make sure not to keep the different outputs powered too long, especially when it comes to the compressor and the defrost output. There is no automatic function limiting the on-time of these functions, as they are only to be used by people with the right skill level.

Entering the test of inputs and outputs:

- In order to access the test program (Setting group “tEs”) press and hold  and  simultaneously for 5 sec.
- **tEs** will be shown in the display and all outputs will be turned off.
- Press  to access the list of “Setting names”.
- Use  or  to choose between the different setting names.
- Press  in order to test the chosen input or output. Read out will be shown and if the setting name is related to an output, this output will be powered on.
- Press  to turn off the I/O being tested, and revert to setting name.
- Press  twice to exit the test program.

Relation	Setting Group	Setting names	Parameter name	Display read out	Output status
I/O	<b>tEs</b>				
I/O		P1	Room sensor	Actual temp on P1*	N/A
I/O		P2	Evap. sensor	Actual temp on P2* (only on freezers)	N/A
I/O		Id1	Digital input (DOOR)	State of digital input shown in display 0 = open contact, I = closed contact **	N/A
I/O		rE1	Relay 1 (COMPRESSOR)	On	ON
I/O		rE2	Relay 2 (DEFROST/DRIP TRAY HEATER)	On	ON
I/O		SSr	SSR output (LIGHT)	On	ON
I/O		dCO	12V dc out (EVAP FAN)	On	ON

(\*) The temperature displayed during the read out of the sensor, is the exact temperature related to the probe resistance. No programmed temperature differentials or filters will be taken into consideration.

(\*\*) Operating the door switch when the setting name Id1 is activated.

- When the door is open the read out will be I
- When the door is closed the read out will be 0

This makes it easy to determine if the door switch is functioning as it should or not, just by opening the door, which should result in a change of read out from 0 to I. When the door is closed again the read out should change from 0 to I.

By testing rE1 (the compressor output) and at the same time measuring at the compressor connections using a voltmeter, it can easily be determined if there is 230 Volt on the compressor inlet.

The 12V DC Fan (current draw approx. 350 mA), the 230V defrost heater (current draw approx. 440mA) and the drip water heater (current draw approx. 150 mA) connections, (accessible inside the drip water tray), can be checked using a clamp meter, or by disconnecting the plugs and measuring for either 12VDC or 230VAC in the respective connections. If the correct voltage supply is present, but there is no current flow, the connected part must be examined further, as to determine if the part is defective or not.

Know there is a temperature limiter with a cut off temperature of 60°C and a reset temperature of 40°C, in series with the defrosting output. If the defrosting output has been tested for a long time this limiter can be triggered, which can be the reason for no heat being generated by the two heating elements (Thermal cut-off), even though the output is ON.

When it comes to the light, the 230V controller output to the LED driver and the 24V DC driver output are not accessible, without taking the front of the tabletop apart.

## How to physically access the controller

If it for some reason becomes necessary to physically access the controller PCB positioned in the front of the table top, or the related connections (door switch, LED driver or other connections of components wired into the controller e.g. evaporator fan, defrost heater, drip tray heater or compressor, the six screws indicated on the below drawing must be unscrewed totally. This makes it possible to dismantle the complete front piece.

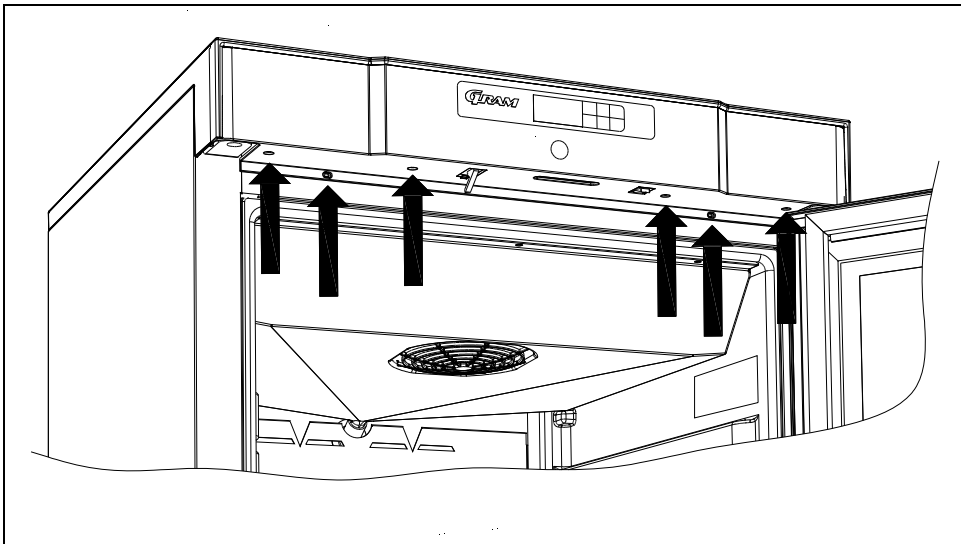

Fig.9



## How to boot the correct software on a spare part controller

If making sure that the controller does have a fault, which can be clearly identified e.g the controller not being able to switch the compressor on/off when using the test of inputs and outputs, and all connections are correct, it can be necessary to replace the controller.

In order to ease the replacement of a defective controller, and to minimize the number of different controllers to have in stock, it has been decided that the controller used for spares is the one with the highest spec. (meaning the fully populated hardware of the KG/FG controller) this controller holds all software versions which do relate to the compact family.

This makes it possible to choose between the different software versions shown below, by booting the controller in a special way.:

### THE BOOTING SEQUENCE IS TO BE DETERMINED

After the above booting sequence, the display read out will be:

S0F - which is short for software

Push the **P** key to see the first possible software which can be chosen, being rE:

in order to navigate between the four different kinds of software use the **←** key and the **+** key.

rE - Refrigerator

rEG - Refrigerator glass door

Fr - Freezer

FrG - Freezer Glass door

When the short for the needed software is displayed, it is chosen by pushing the **P** key.

This will initiate the needed boot sequence for the wanted software.

## How to change the controller

Since the controller and the display foil are attached to each other, by means of double adhesive tape, it cannot be guaranteed, being possible to replace the controller front label without replacing the controller and the other way around.

In order to make the front of the controller “watertight” (IP 65 from the front), the controller label is mounted using a very strong double adhesive layer between the plastic front piece of the tabletop and the controller label. This does at the same time mean that the label is glued to the capacitive touch of the display part. If the controller front label becomes defective due to physical impact of some kind, the controller is no longer protected against water and dust, in the same way as if the label is intact.

There is an imminent risk of breaking the capacitive touch, of the controller, when trying to remove the label. For that reason, the replacement controller and the controller front label should always be changed/and bought as a set.

# Controller layout and description

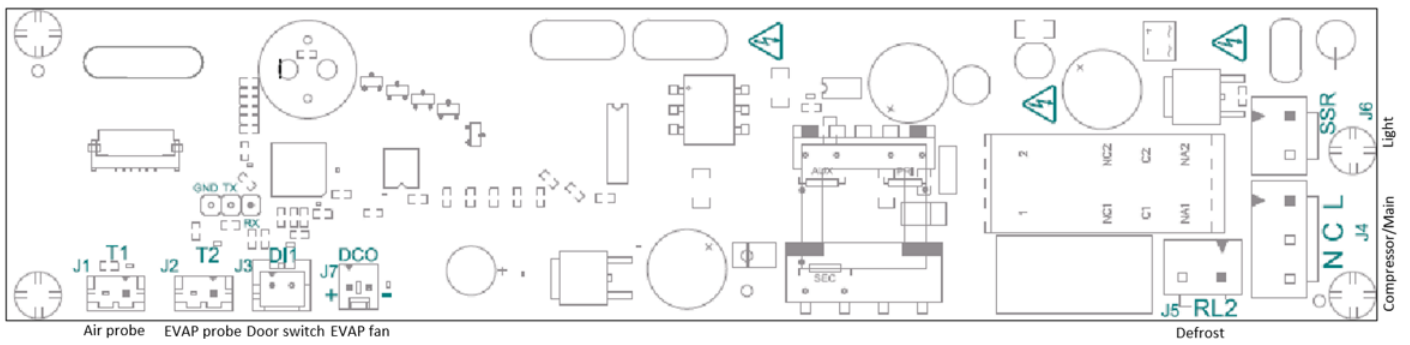

Connectors				Inputs				
Ref.	On board connector	Cable conn.	Constructor	Description	Features			
J1 /T1	B2B-EH-TS	EHR-2	JST	Air probe, NTC5K	range: -30...15°C; accuracy: ±0.1°C			
J2/T2	B2B-EH-TS-E	EHR-2-E	JST	Evaporator probe, NTC5K	range: 16...100°C; accuracy: <±0.5°C			
J3/Di1	B02P-XASK-1-A	XAP-02V-1	JST	Door Switch	Digital input: 5V; 100 Ohm max.			
Connectors				OUTPUTS				
Ref.	On board connector	Cable conn.	Constructor	Description	Model	Type of load	Rating@230Vac	Cycles
J4/RL1	B03P-NV	NVR-03	JST	Neutral/Compressor/Live	G2RL	Inductive	4FLA; 24LRA	100K
J5/RL2	B02P-NV-BL	NVR-02-E	JST	Defrost	G5Q	Resistive	4A (N.O.)	100K
J6/SSR	B02P-NV	NVR-02	JST	Lights	SSR	---	0.5A	---
J7/DCO	2227-2021	2201-2021	MOLEX	Evaporator fan	Open collector	SELV	12Vdc, 350mA	---
<b>Power supply</b>				<b>Operating conditions for controller</b>				
100...240Vac ±10%, 50/60Hz				Temperature between -10 and +50°C Relative humidity Between 15 and 80%				

## Reversing the glassdoor

When changing the glass door from a right version to a left version, the self closing device and the bronze bushing hinge must change position.

Inside the frame behind the self close device is the LED light cord. This must be pulled out and now go through the bronze bushing.



When switching to **left version**, the lower hinge must be replaced.

Lower Left hinge – Item number	Lower Right hinge – Item number
762222830	762222829

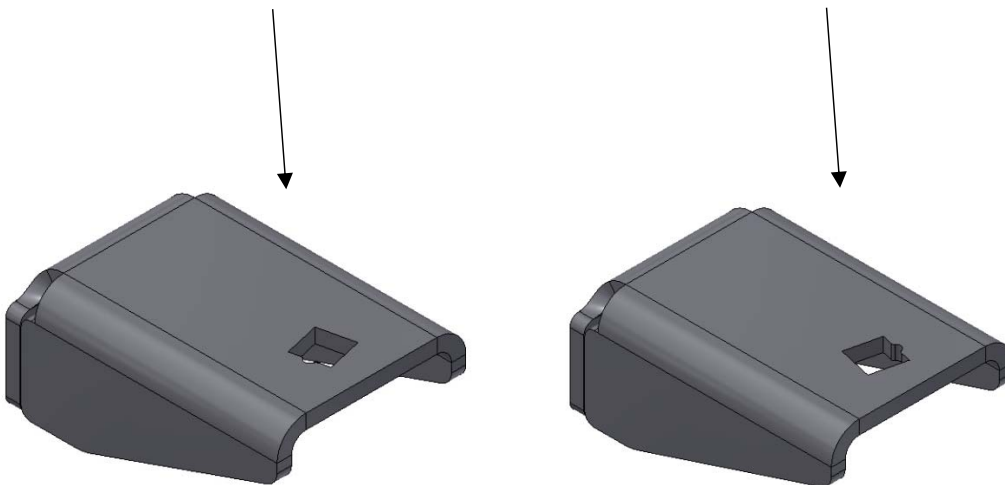

# EC-Declaration of conformity

**Producer** Name: Gram Commercial (CVR-nr. 41423986)  
Address: Aage Grams Vej 1, 6500 Vojens  
Tel.: +45 73 20 12 00

**Product** Model: Compact 220  
Compact 320  
Compact 420

Refrigerant: R600a

Year: 2020

**Directives** The product is in compliance with all the essential health- and safety requirements and provisions in:

**Directive for Machinery 2006/42/EF**

The product is where relevant in compliance with the following other directives:

**Electromagnetic Compatibility Directive – 2014/30/EU**

**Design of energy related products 2009/125/EF**

**Regulation 2015/1095**

**FCM regulation 10/2011**

**Regulation 1935/2004**

**RoHS 2 - 2011/65/EU**

---

**ROHS 3 - (EU) 2015/863**

**Standards** The following standards are used to the extent necessary to comply with the relevant directives:

**DS/EN 12100:2011** - Safety of machinery -- General principles for design -- Risk assessment and risk reduction

**DS/EN 60335-1:2012** – Household and similar electrical appliances. Safety. General requirements

**DS/EN 60335-2-89:2010** – Household and similar electrical appliances. Safety. Particular requirements for commercial refrigerating appliances with an incorporated or remote refrigerant condensing unit or compressor

**DS/EN ISO 22041:2019** – Refrigerated storage cabinets and counters for professional use. Performance and energy consumption

**Person responsible for technical dossier** Company: Gram Commercial (CVR-nr. 41423986)  
Address: Aage Grams Vej 1  
Name: John Lund

**Signature** Vojens 29/10-2020 R&D Manage



# Wiring diagram – K 220/320/420

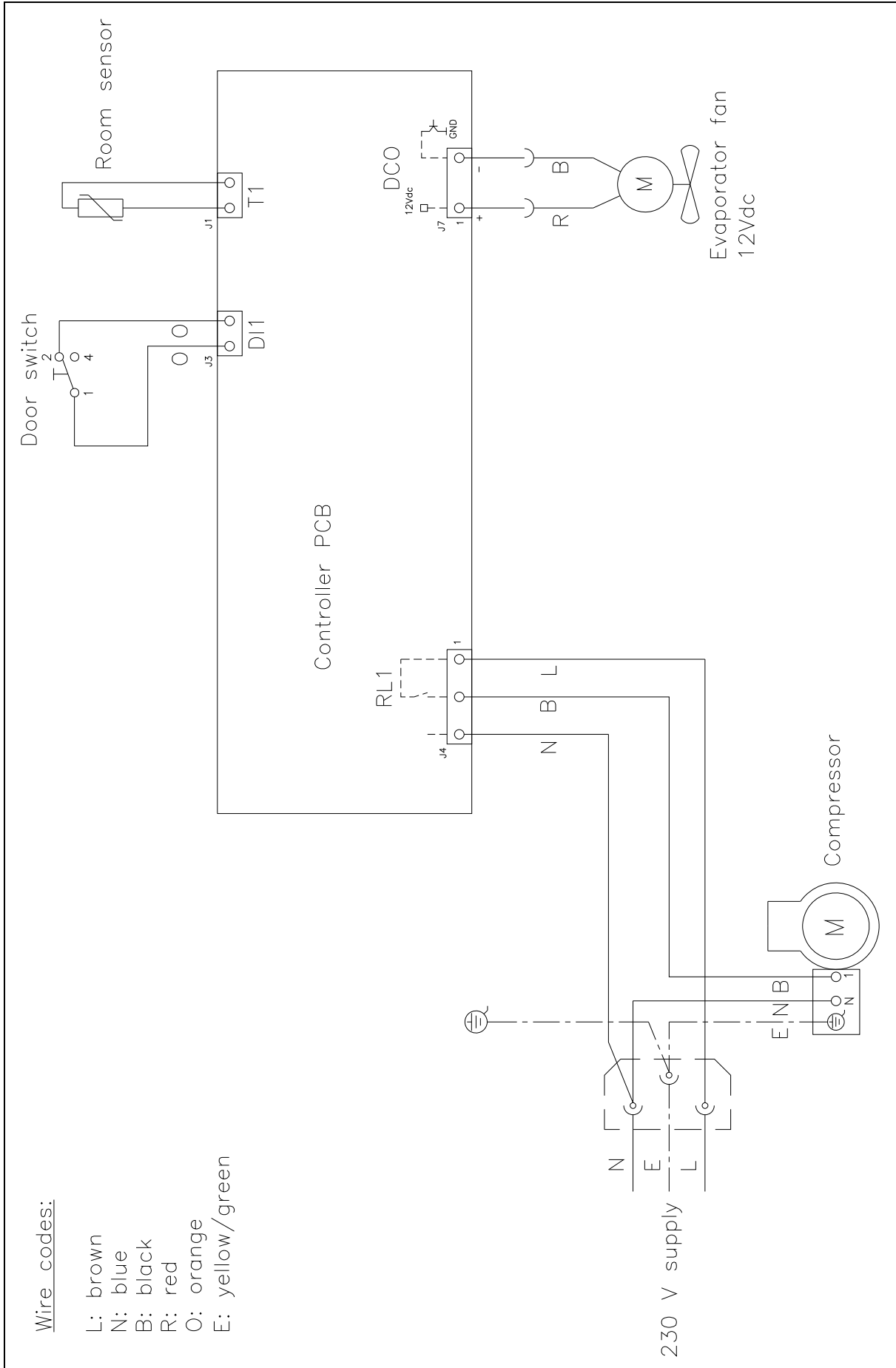

# Wiring diagram – KG 220/320/420

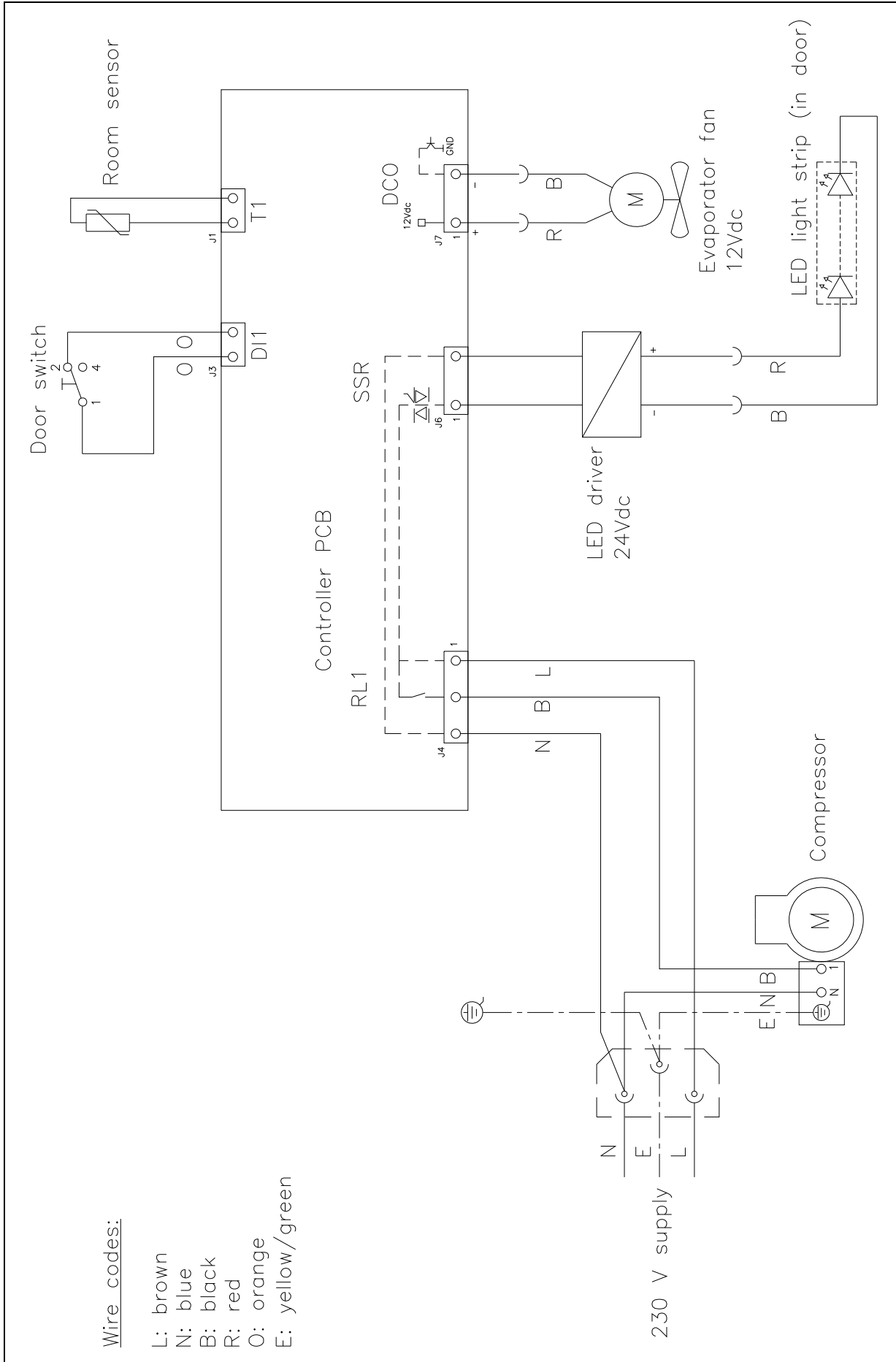

# Wiring diagram – F 220/320/420

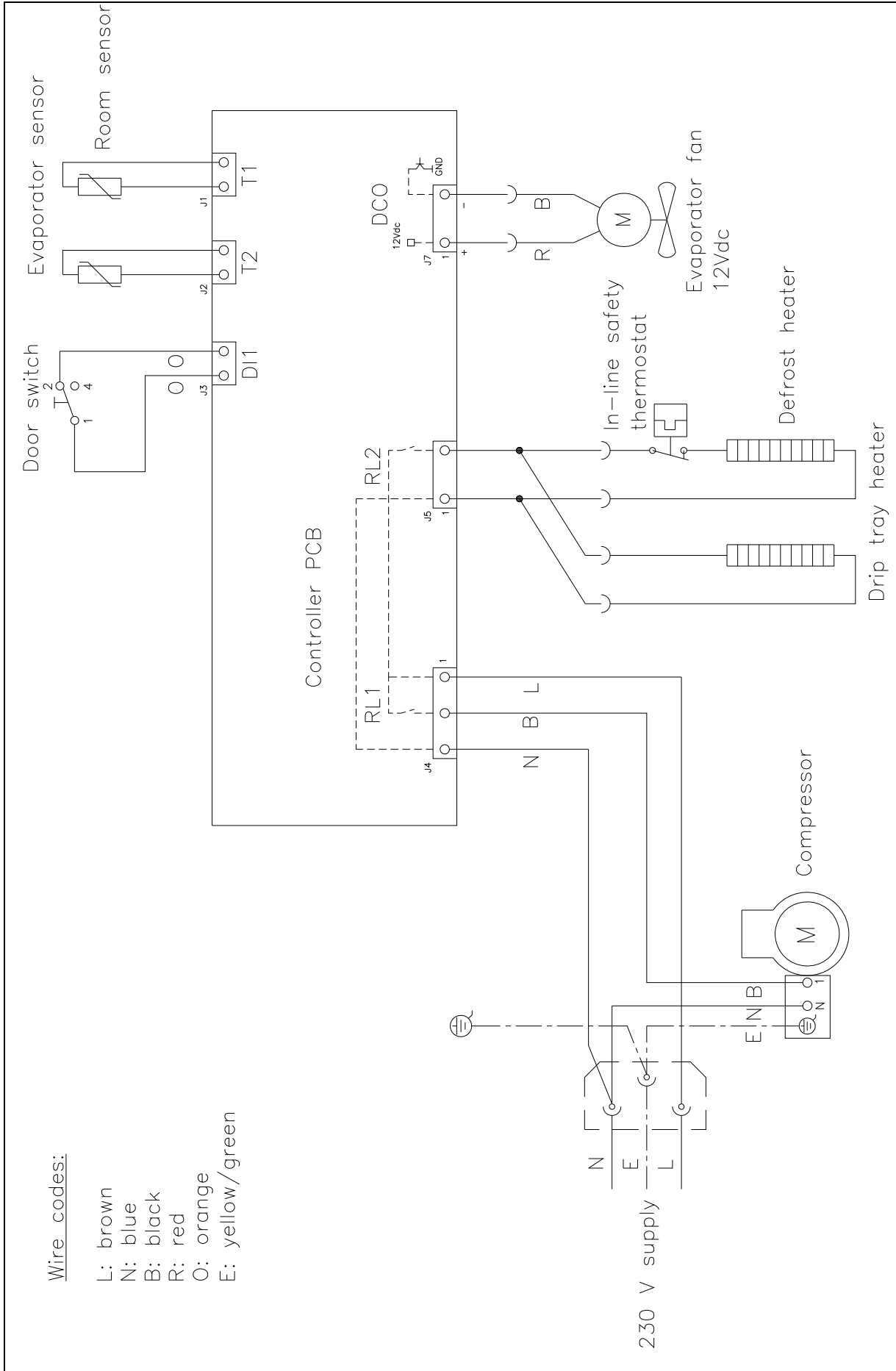

Wire codes:

- L: brown
- N: blue
- B: black
- R: red
- O: orange
- E: yellow/green

# Wiring diagram – FG 220

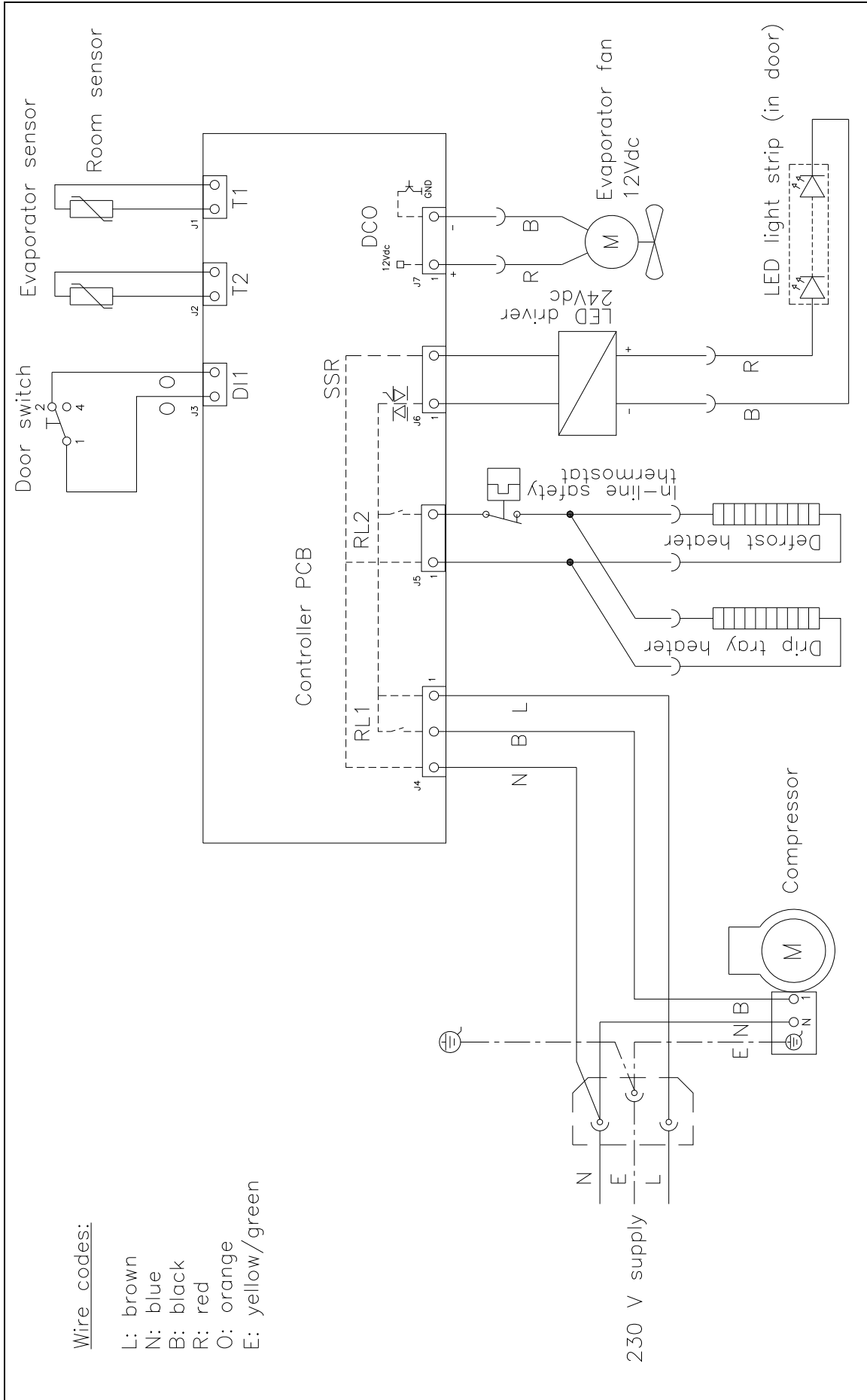



# Piping diagram

K/KG 220/320/420

F/FG 220/320/420

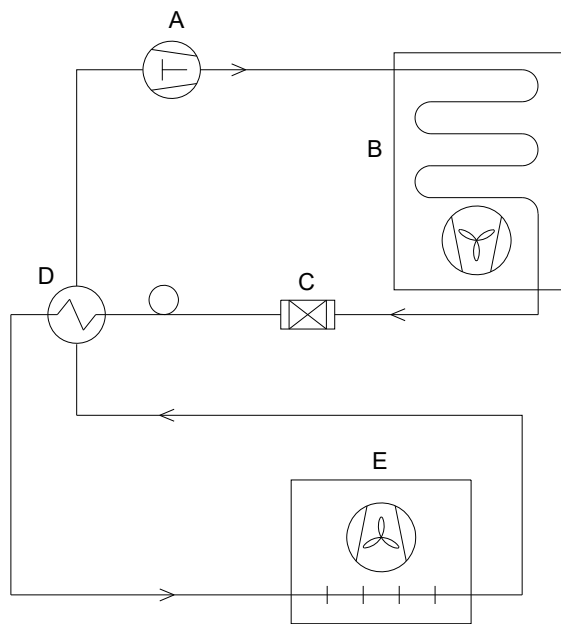
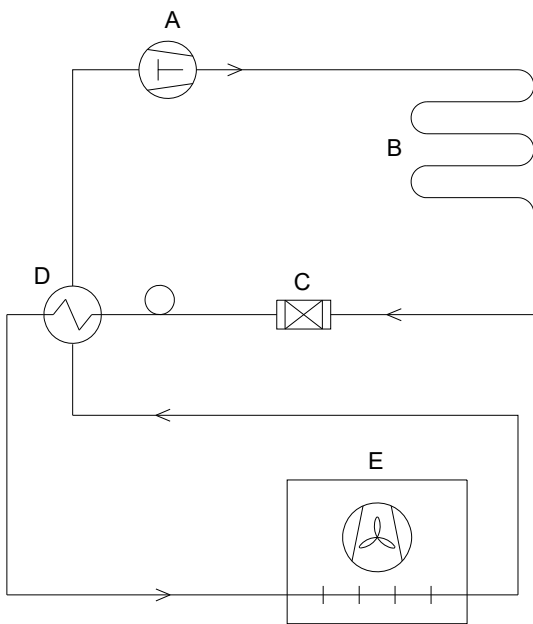

	DK	GB	D
A	Kompressor	Compressor	Kompressor
B	Kondensator	Condenser	Verflüssiger
C	Tørrefilter	Filter drier	Trockenfilter
D	Varmeudveksler	Heat exchanger	Wärmeaustauscher
E	Fordamper	Evaporator	Verdampfer