



Project _____

Item # _____

Quantity _____

Rapide Cuisine® Drop-In High-Powered/Heavy-Duty Induction Ranges

Models: IRNG-PB1-30, -36

Hatco's Rapide Cuisine® Drop-In High-Powered/Heavy-Duty Induction Range offers industry-leading features and true back-of-house power in a commercial kitchen-proof package.

The unit can be mounted flush or near flush with an optional trim ring. It features our Magnetic Power System (MPS) to deliver the highest power in its class! It has User Programmable Presets (UPP) for repeat menu items and a food temperature probe for more accurate cooking, plus a timer, high resolution color display and convenient power and temperature modes.

Standard features:

- Four surface temperature sensors offer the most accurate control in its class
- Culinary equivalent of up to 31,000 BTUs gas
- High resolution TFT (thin film transistor) display instantly advises the operator of precise power (1 to 100), temperature (°F or °C in one degree increments) and time control (30 seconds to 10 hours)
- Programmable mode so the operator can create preset programs for consistent cooking cycles
- Includes conformal-coated boards
- Easy to use color-coded selectable functions
- Large adaptive control for precise, fine control (slow turns) to spanning the full range in a single twist (fast turns)
- Pan Sense Technology (PST) activates the unit only when a suitable pan is placed on top
- Patterned, glass-ceramic top that is durable, easy to clean and helps scratches from heavy use become less noticeable
- Easy to clean, fully sealed top stops grease or moisture from penetrating the unit, even if the top gets broken
- Automatic shut-off to prevent overheating
- Withstands high ambient kitchen temperatures (up to 124°F/51°C)
- USB port for downloading updates
- Includes a remote control panel and cord
- 71" (1800 mm) cord with plug



IRNG-PB1-36 shown in standard finishes

Includes a food temperature probe which facilitates highly accurate cooking

Accessory (available for purchase at any time)

- Trim Ring* in Stainless Steel (holds unit nearly flush on a stainless steel counter [TRIM-PB1-36])

*For use where chair-step routing of the countertop material is not possible, but a flush-mounted look is desired.



For operation, location and safety information, please refer to the Installation and Operating Manual.



HATCO CORPORATION | P.O. Box 340500 Milwaukee, WI 53234-0500 U.S.A. | (414) 671-6350



www.hatcocorp.com | support@hatcocorp.com | [Find a Hatco Rep](#) | [Image Library](#) | [Document Library](#) | [Patents](#) | [Chat](#)



Rapide Cuisine® Drop-In High-Powered/ Heavy-Duty Induction Ranges

Models: IRNG-PB1-30, -36

IRNG-PB1-30, -36 Models

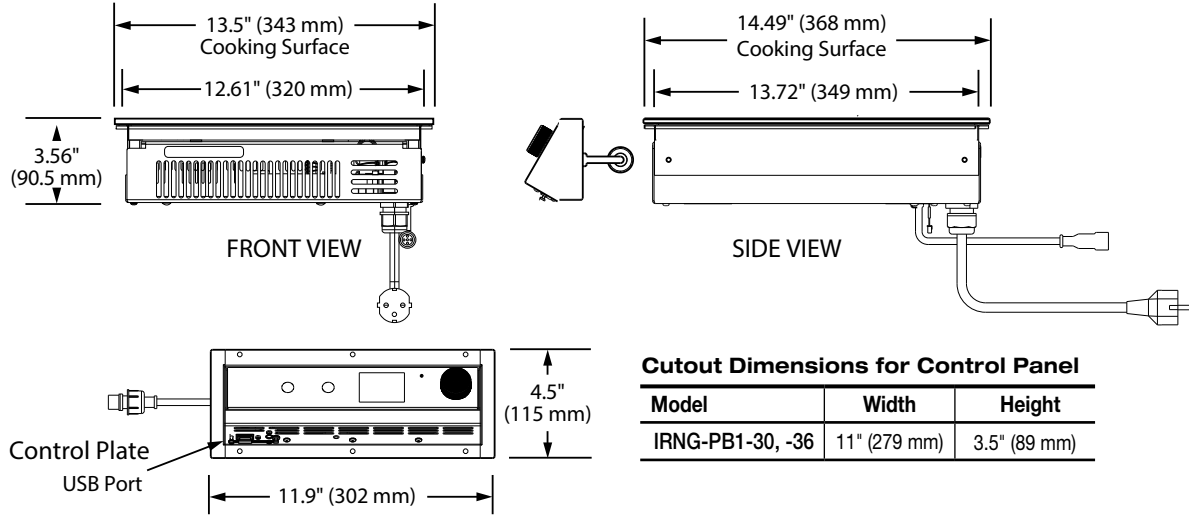

IRNG-PB1-30-36 Model Cutout Dimensions

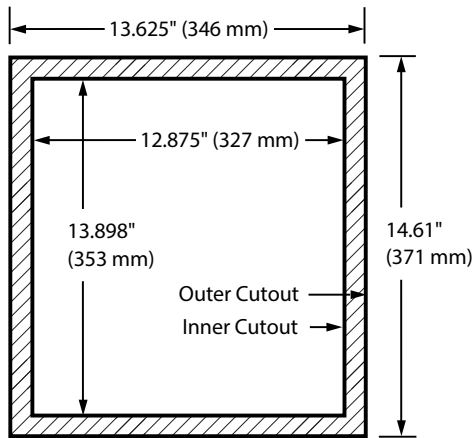

Cutout Dimensions for Flush Mount

Model	Outer Cutout		Inner Cutout	
	Width	Depth	Width	Depth
IRNG-PB1-30, -36	13.625" (346 mm)	14.61" (371 mm)	12.875" (327 mm)	13.898" (353 mm)

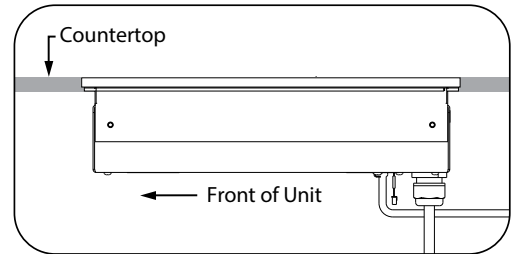
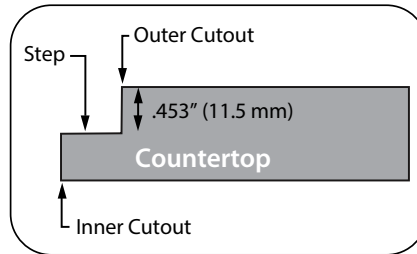

Cutout Dimensions for Trim Ring for IRNG-PB1-30, -36 (holds unit nearly flush on a stainless steel countertop)

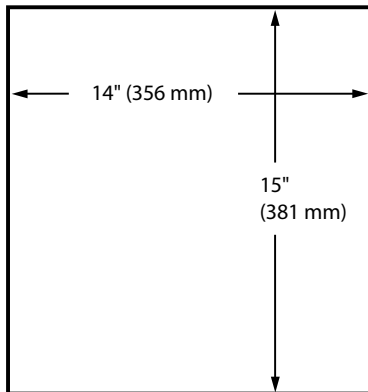

Cutout Dimensions for Trim Ring

Model	Width	Depth
IRNG-PB1-30, -36	14" (356 mm)	15" (381 mm)

Cutaway view of Trim Ring

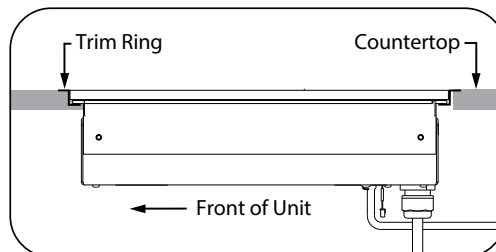

HATCO CORPORATION

P.O. Box 340500 Milwaukee, WI 53234-0500 U.S.A. | (414) 671-6350



www.hatcocorp.com

support@hatcocorp.com

[Find a Hatco Rep](#)

[Image Library](#)

[Document Library](#)

[Patents](#)

[Chat](#)



Rapide Cuisine® Drop-In High-Powered/ Heavy-Duty Induction Ranges

Models: IRNG-PB1-30, -36

IRNG-PB1-30, -36 Model Ventilation Requirements

Clearances: 2" (51 mm) for front and sides.
Minimum 6" (152 mm) for rear.

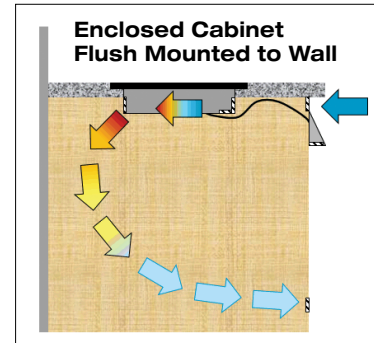
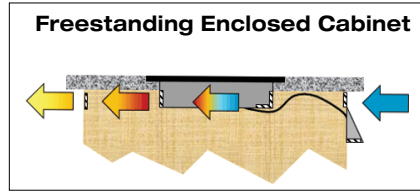

Cabinets should be sufficiently open to allow fresh air to cool the units. Two areas equal to 20 sq. inches (129 sq. cm) each should be provided for each unit. These should be located as close as possible to the intake

(front) and exhaust (rear) sides of the unit. In cases where the cabinet is located against a wall, install one opening near the control panel and the other toward the bottom of the cabinet.

SPECIFICATIONS High-Powered/Heavy-Duty Drop-In Induction Ranges

The shaded areas contain electrical information for International models

Model	Dimensions (Width x Depth x Height)	Volts	Phase	Watts	Amps	Plug	Cord Location	Approx. Ship Weight
IRNG-PB1-30	13.5" x 14.49" x 3.56" (343 x 368 x 91 mm)	220 (CE)	Single	2860	13.0	BS 1363	Rear left bottom base corner	22 lbs. (10 kg)
		230 (CE)		2990				
		240 (CE)		3120				
		220/60		2860				
IRNG-PB1-36	13.5" x 14.49" x 3.56" (343 x 368 x 91 mm)	220 (CE)	Single	3300	15.0	CEE 7/7 Schuko, AS 3112	Rear left bottom base corner	22 lbs. (10 kg)
		230 (CE)		3450				
		240 (CE)		3600				
		208		3120		NEMA 6-20P		
		240		3600				

PAN SIZE

Maximum Pan Size: 14" diameter (356 mm), Minimum Pan Size: 4" diameter (102 mm).

PLUG CONFIGURATIONS

BS 1363

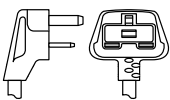

CEE 7/7 SCHUKO

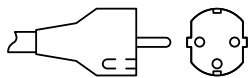

NEMA 6-20P

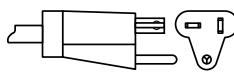

AS 3112

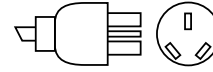

PRODUCT SPECS Rapide Cuisine® Drop-In High-Powered/ Heavy-Duty Induction Ranges

The High-Powered/Heavy-Duty Drop-In Induction Range shall be a Rapide Cuisine® model, manufactured by the Hatco Corporation, Milwaukee, WI 53234 U.S.A. The Induction Range shall be rated at ... watts, ... volts, single phase and be ... inches (millimeters) in overall width. The Drop-In Induction Range shall consist of a stainless steel and aluminum housing with a single generator coil, a glass-ceramic top surface, food temperature probe and a 71" (1800 mm) cord and plug. It shall include a remote control box with a glass touch panel, a color-coordinated control (CCC) for 0-100%

power levels and temperature control in F° or C°. The range will be controlled via an infinite control and feature a USB port (for updates and future access to additional operating modes) and a 51" (1300 mm) cable. The remote control box is connected to the main case with a quick disconnect connector. A food temperature probe and 71" (1800 mm) cord and plug is included.

Warranty consists of 24/7 parts and service assistance (US and Canada only).

HATCO CORPORATION | P.O. Box 340500 Milwaukee, WI 53234-0500 U.S.A. | (414) 671-6350



www.hatcocorp.com | support@hatcocorp.com | [Find a Hatco Rep](#) | [Image Library](#) | [Document Library](#) | [Patents](#) | [Chat](#)