

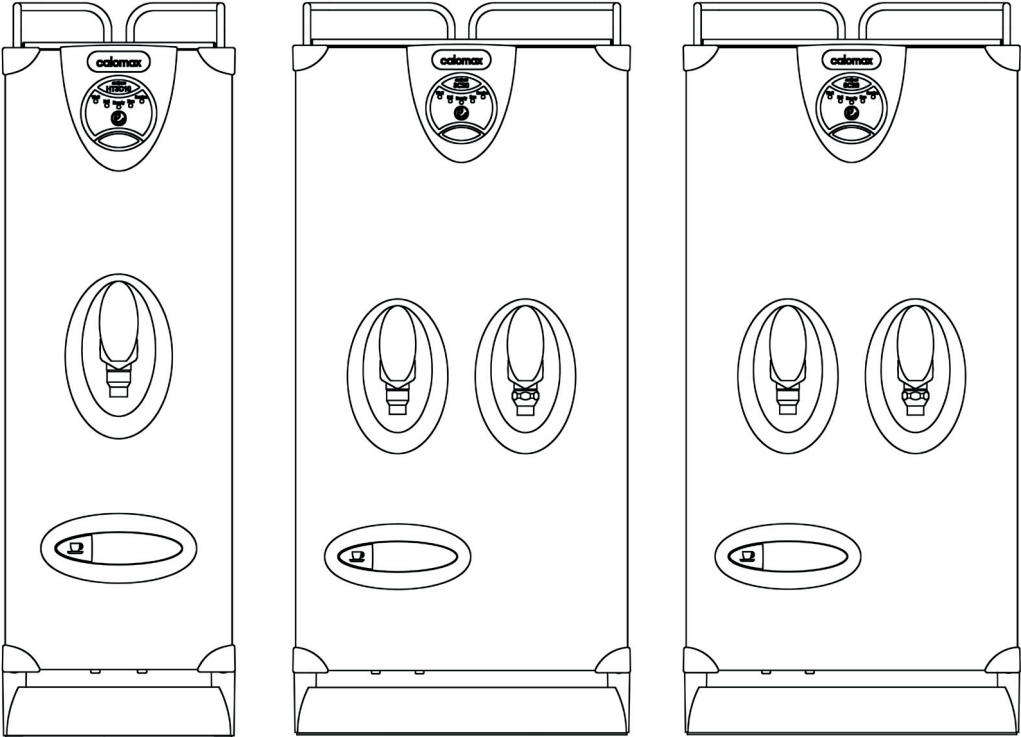

INSTALLATION, OPERATION AND SERVICING INSTRUCTIONS
FOR THE ECLIPSE HT3C10, HT3C20 and HT6C20 WATER BOILERS



Issue 6
08/12/2021
DCR: 1064



Please read these instructions carefully before operating your boiler for the first time



Calomax Limited
Lupton Avenue, Leeds LS9 7DD
Tel. 0113 249 6681
e-mail: service@calomax.co.uk www.calomax.co.uk

CONTENTS	PAGE
INTRODUCTION	3
CHECK LIST	3
APPROVALS	3/4
CONSTRUCTION	4
INSTALLATION AND MAINTENANCE	4
LOCATION	4
COLD WATER INLET	5
ACCESS INSTRUCTIONS	5/6
VENT / OVERFLOW	6/7
ELECTRICAL CONNECTIONS	8
USER INSTRUCTIONS	8/9
SCALE	9
CLEANING	9
GENERAL OPERATION	10/11
TROUBLE SHOOTING	12
ACCESSORIES	13
SPARE PARTS	14/15
EXPLODED DIAGRAM	16/17/18/19/20/21
SERVICE INSTRUCTIONS	22/23
GENERAL FUNCTION	24
WIRING DIAGRAMS	25/26
WARRANTY	27
PRODUCT SPECIFICATION	28

INTRODUCTION

Thank you for purchasing a boiler from the Calomax Eclipse range. All our products are designed to give years of simple, reliable operation. To ensure this, it is important that the installation and subsequent servicing and maintenance is carried out by a suitably qualified engineer in accordance with these instructions.

For assistance in finding a suitable engineer in your area, visit our website www.calomax.co.uk, contact our service department on 0113 249 6681 or e-mail: service@calomax.co.uk

CHECK LIST

Before commencing installation, check that the following parts have been supplied with the boiler:

1. WRAS approved flexible water inlet hose suitable for potable water.
2. Drip tray kit

APPROVALS



This product conforms to the CE and UKCA marking directive through compliance with the following standards:

- The Low Voltage Directive 73/23/EEC
- The Electromagnetic Compatibility Directive 89/336/EEC

Compliance with these standards has been confirmed through testing by an independent NAMAS approved body.

Any water fittings or water-using appliance connected to the mains water supply must comply with the Water Fittings Regulations (or Byelaws in Scotland). This ensures the appliance does not waste or contaminate the drinking water supply. In order to demonstrate compliance, this product has been submitted to the Water Regulation Advisory Scheme (WRAS) and proven to conform to these regulations.



The tap handle, drip tray and cup stand mouldings incorporate the Steritouch additive and have been independently tested to prove the effectiveness of the surface hygiene

CONSTRUCTION

All metallic components of the machine, in direct contact with drinking water are manufactured from high quality 316 grade stainless steel, or non-ferrous materials, providing maximum resistance to corrosion.

INSTALLATION AND MAINTENANCE

LOCATION

The boiler must be installed in a location where access is restricted to operators that are suitably trained, or where untrained operators of the machine can be supervised by trained personnel.

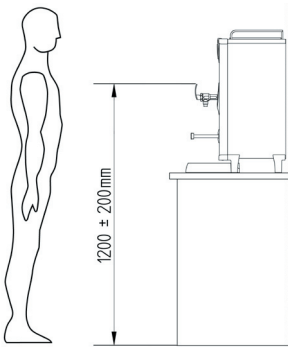

To comply with recommendations from the Health and Safety Executive it is important that due consideration be given to safe operation of the controls of the boiler. The boiler should therefore be positioned in such a manner that the operator can stand directly facing the machine with the controls at a recommended height from the floor to the draw-off tap handle of 1200mm +/- 200mm.

Consideration should also be given to the servicing requirements of the machine and individual user requirements must always be taken into account. The minimum and maximum ambient operating conditions are 5 °C and 35 °C respectively. The appliance is not suitable for installation where a water jet could be used. Install the boiler on a surface suitable for the working weight of the boiler. Allow clearance for ventilation and for the easy removal of the outer casing lid and front panel. Calomax recommend a minimum clearance of 50mm on all sides of the boiler. A suitably qualified engineer should install this unit. Plumbing and electrical installation work may be involved.

COLD WATER INLET

TO COMPLY WITH UK WATER SUPPLY REGULATIONS A SINGLE CHECK VALVE MUST BE FITTED.

BEFORE CONNECTING, THE SUPPLY PIPE MUST BE THOROUGHLY FLUSHED OUT TO ENSURE THAT FOREIGN MATTER DOES NOT BLOCK OR ENTER THE SOLENOID VALVE

The boiler must be connected to a potable water supply using the food grade hose provided, or rigid 15mm pipe in a manner which complies with UK water regulations via an appropriate isolating valve. Always use the new hose supplied. Do not reuse old hoses. Do not use red or blue washing machine hoses as these will impart an unpleasant taste to the water. The water supply must provide a constant pressure of between 20 KPa and 1000 KPa (0.2 to 10 Bar).

If the water supply contains solids in suspension it is recommended that an "in line" water filter is fitted in the pipe work. Problems caused by scale and sediment are not covered by the warranty.

ACCESS INSTRUCTIONS

Access to the internals of the machine is gained by the removal of the front panel. It is advised to remove the cup stand drawer before removing front panel. To remove the drawer pull the latch up underneath the cup stand and slide the stand out. Calomax advise to place the drawer back in its housing after the front panel has been screwed back into place to avoid damage. When replacing the drawer ensure there are no wires trapped behind the drawer to avoid pulling them out.

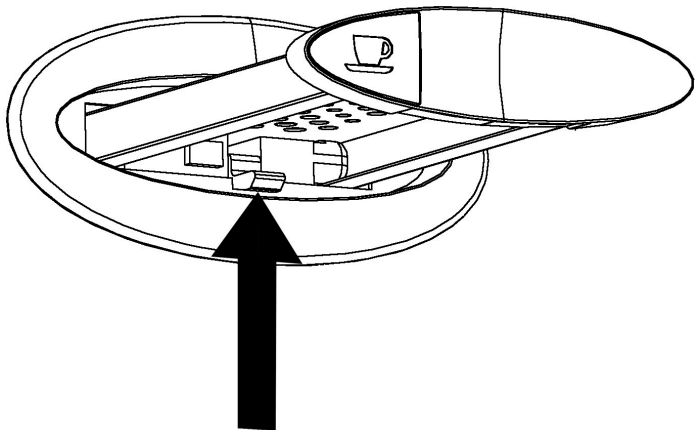

After removing the cup stand pull off the outercasing lid from its mounting clips. Do not pull the cup rails as this may damage the lid. Remove the top two panel mounting screws. The cover is secured with clips at the bottom of the panel and must be pulled off to gain access to the internal workings of the boiler.

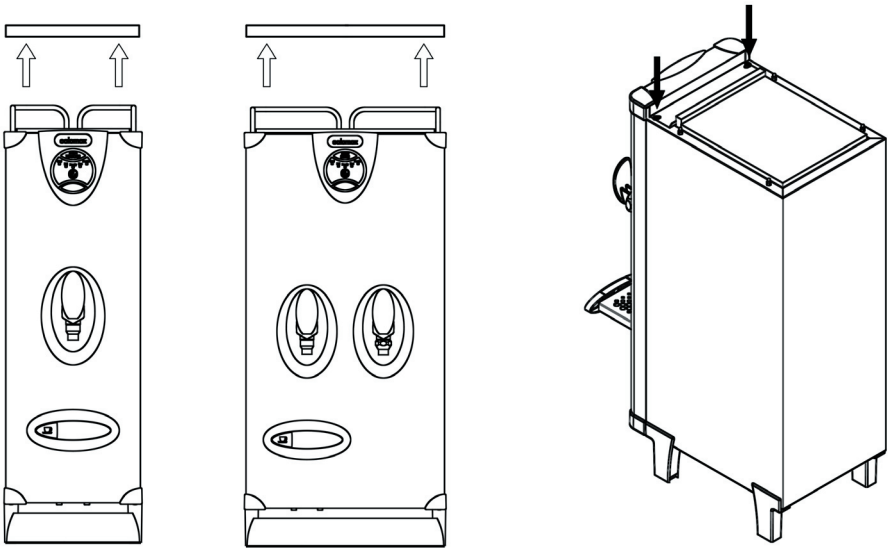

VENT / OVERFLOW

The vent/overflow pipe should be extended and laid with a **continuous fall**, discharging to a safe and visible point via either of the two options advised: '**Via the drip tray**' or '**By-passing the drip tray**', both options are shown on the opposite page. The pipe should not be directly connected to a closed waste, as taste problems may occur and should never be allowed to become blocked or restricted. 15mm copper or 'Speedfit' pipe should be used.

If the machine is installed without the vent / overflow pipe being extended as advised, any subsequent damage incurred will be the responsibility of the installer. Further information, including diagrams, can be found under the 'Installation Guide' section on our website.

The boiler will have a packaging cap on the vent / overflow pipe underneath the boiler. THIS MUST BE REMOVED. Pull this off in the direction of the arrow.

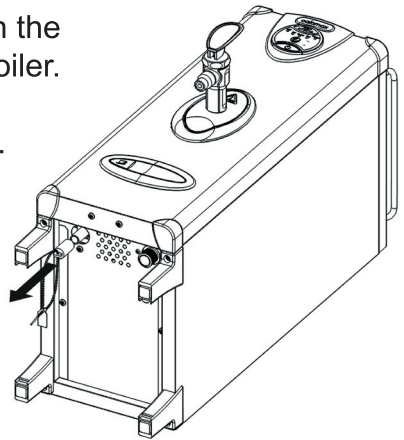

VENT / OVERFLOW CONFIGURATION OPTIONS

Via the drip tray

Remove the packaging cap and replace the end stop on the back of the drip tray with the straight push fit connector supplied. Then connect 15mm pipe to the other end of the connector and run it to a safe and visible point of discharge.

By-passing the drip tray

Remove the packaging cap and attach the elbow push fit connector to the vent / overflow pipe on the bottom of the boiler. Then connect 15mm pipe to the other end of the connector and run it to a safe and visible point of discharge.

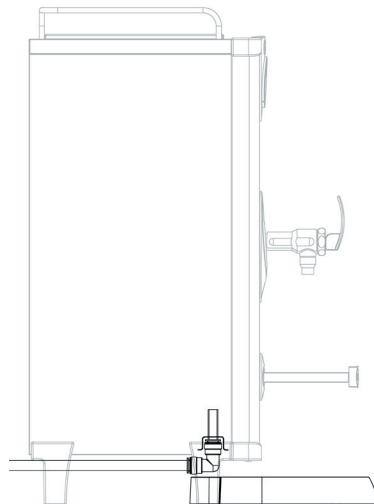
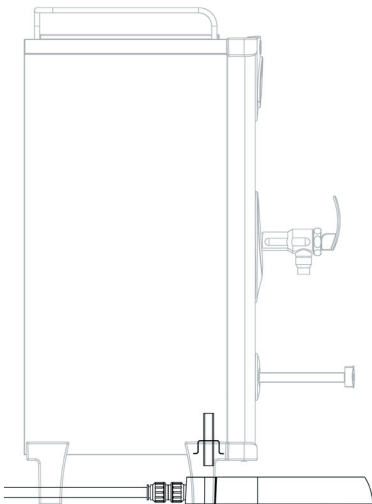

ELECTRICAL CONNECTIONS

The 3kW models should be connected to a 240V ac 13A electrical supply, via the fitted plug and lead.

The 6kW models require fixed wiring to the internal terminal block. A means of disconnection must be provided in which at least 3mm separation between the live and neutral poles of the supply exist.

The 6kW models require the connection of an equipotential bonding conductor. This is located on the tap bracket inside the boiler, accessible when first installing the boiler. It is indicated by the equipotential symbol.



The installation of a residual current device (RCD) having a rated residual operating current not exceeding 30 mA is advisable.

USER INSTRUCTIONS



During normal operation some external parts will become very hot, particularly the tap body. Care must be taken to avoid injury, a burn or scald.

Only authorised personnel who have been instructed in the safe and proper use of the equipment should be allowed to use this machine. Boiling water is discharged from the tap and due care and diligence should be exercised at all times.

In the event of the power supply lead to the boiler becoming damaged, the appliance must be removed from service. For 3kW models, a replacement genuine part is available from Calomax which must be fitted by a suitably qualified engineer in order to avoid a hazard.

COMMISSIONING

Turn on the water supply and then switch on the electrical supply. When the power switch is pressed on the front fascia the 'Wait' light will illuminate and the unit will fill with water at a flow rate of 1.3 L/Min. When water reaches the low water level sensor, the element will be energised and the solenoid will continue to fill the boiler to the normal operating water level. When the water has reached the normal operating temperature, the 'Wait' light will extinguish and the 'Ready' light will illuminate. At this time the 'Full' light will be illuminated indicating that the machine has reached full capacity of boiling water.

SUBSEQUENT USE

After the boiler has finished the commissioning cycle and water is drawn from the tap, water will be replenished in short cycles (small volume of water and then heat). The solenoid and element will never be on at the same time unless the boiler is switched off and on again (re-setting commission mode). In normal use the boiler will always be at operating temperature indicated by the 'Ready' light being illuminated. The 'Full' light will be illuminated only when the boiler is full of boiling water. By pressing the 'e' symbol on the upper fascia panel, the 'Eco' feature is selected. This feature reduces the working capacity of the appliance by approximately half. The 'Full' light will be disabled.

SCALE

The production of scale is a natural phenomenon and commonly occurs in hot water systems. The nature of the scale produced and its rate of formation varies widely throughout the country.

To ensure continuous, reliable operation, the boiler should be regularly de-scaled by a suitably qualified engineer.

The Eclipse boiler benefits from an integral scale inhibitor. **This is not** a scale *eliminator* and its effects will differ according to the water quality in your area. To ensure trouble free operation, periodically check for scale inside the boiling chamber. De-scaling may be required within the first 12 months. This is not covered under the product's warranty as it is not a fault. Further information on scale, including a postcode search facility for water hardness in your area can be found under the 'Water Filter Advice' section on our website.

CLEANING



Avoid using any abrasive materials. Wiping the outer casing with a damp cloth should be sufficient. Some stainless steel cleaning products may not be suitable for plastic and must not come in contact with the plastic fascia parts. Always disconnect the electrical supply before cleaning.

NEVER USE A SPRAY JET OR ANY OTHER METHOD WHICH COULD CAUSE WATER TO ENTER THE ELECTRICAL CHAMBER.

GENERAL OPERATION

- To use the cup stand press the cup icon. The tray will spring forward and can then be pulled out to its maximum extent. Reverse the procedure when the tray is not required.

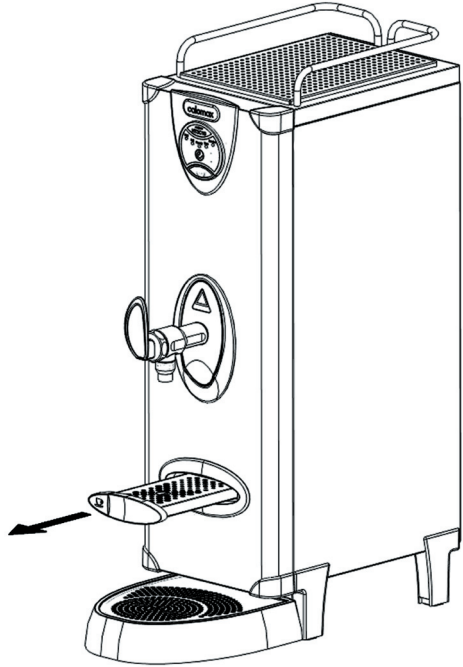
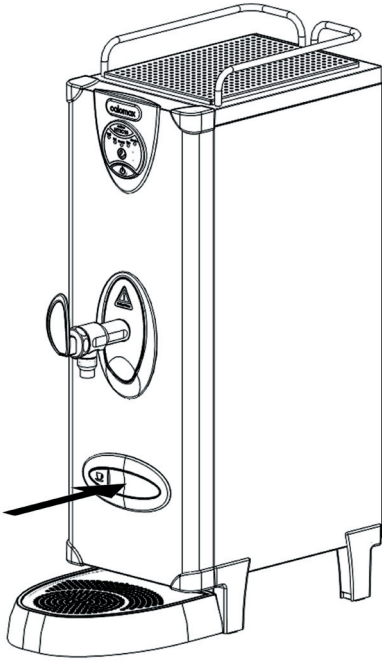

- Hold a cup below the tap or place on the cup stand. Large vessels should be stood on the main drip tray. Care must be taken to avoid injury through splashing or over-filling.

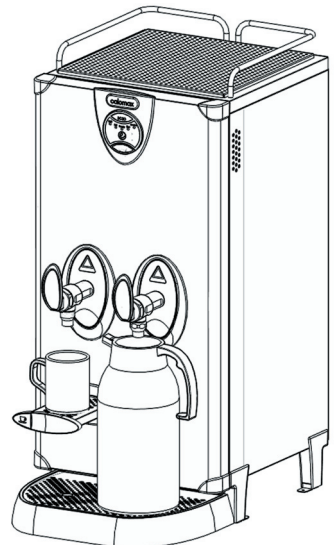

- To begin filling, pull the handle forward or push it backward; hot water begins to flow. If the tap is opened fully forwards it can be locked open (for filling large vessels). In this state the boiler must never be left unattended.

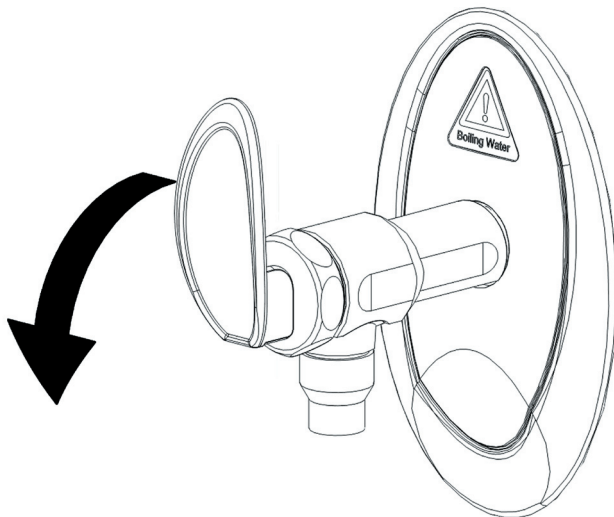

- To stop filling, return the handle to the closed position.

- The HT3C20 and HT6C20 models have two tap handles. The handle on the left has the cup stand underneath the tap. This is the side advised for filling cups and mugs. The handle on the right has a quick flow nozzle resulting in a faster flow of water out of the tap. Calomax advise that this side is used to fill up larger vessels, not cups or mugs.

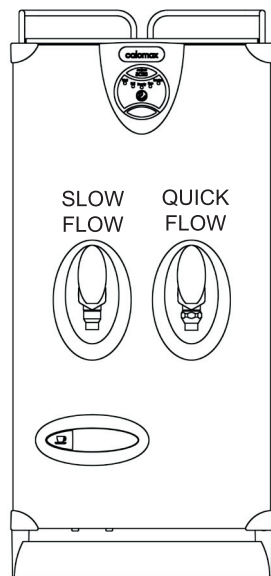

BASIC TROUBLE SHOOTING

Symptoms	Possible Cause	Remedy
No boiling water available	Broken tap top	Replace tap top (or component)
	Element failed or tripped	Replace element or reset trip
	Over-boil cutout tripped	Reset trip device
	Defective Printed Circuit Board	Replace Circuit Board
Overboiling	Excessive internal scale. (See 'De-Scale' page 23)	De-scale the boiler (Particularly thermistor)
	Faulty wiring to thermistor / faulty thermistor	Repair / replace as required
	Temperature controller needs adjusting	Lower operating temperature
	Element failed to earth	Replace element
	Defective Printed Circuit Board	Replace Circuit Board
Overflows	Dirt in solenoid valve.	Clean solenoid filter or replace solenoid, "work the boiler" - see Service Instructions.
	Level sensors require de-scaling or replacing	De-scale / replace sensors
	Defective Printed Circuit Board	Replace Circuit board

Thermal Cutout Devices.

The HT3C10, HT3C20 and HT6C20 boilers have an inbuilt thermal cutout device to protect the element in a boil dry situation. They also feature an inline thermal cutout device on the vent / overflow pipework to detect and cut power in the event of an over-boil situation. Should either cutout be activated, contact our service department or an approved Calomax service provider for advice.

ACCESSORIES

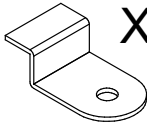

X4

Securing clamp kit
Ref. MFK

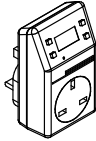

Plug-in time switch
Ref. 7DPIT
Max 3 kW

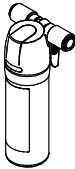

Water filter kit
(To reduce taste & odour problems)
Ref. CWFK

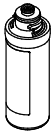

Filter Cartridge
(Replacement filter for kit shown above)
Ref. CWFC1

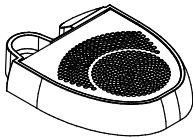

Eclipse drip tray kit black
Ref. EDTKKB

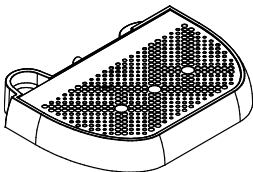

Eclipse large drip tray kit black
Ref. ELDTKKB

For more information visit our website at www.calomax.co.uk or call 01132496681

Spare parts are usually available ex-stock from our online shop.
Please quote Model & Serial Number if unsure.

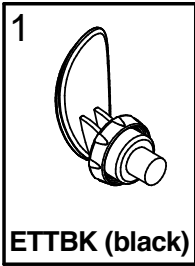

TAP TOP
ASSEMBLY

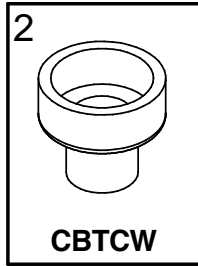

TAP CUP WASHER

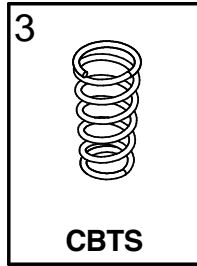

TAP SPRING

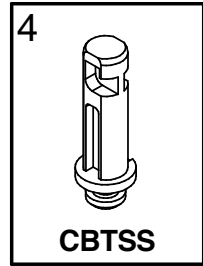

TAP SLOTTED
STEM

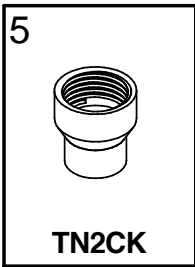

SLOW FILL NOZZLE

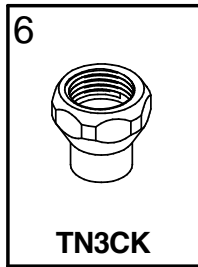

FAST FILL NOZZLE

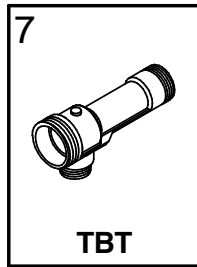

DRAW OFF TAP
BODY

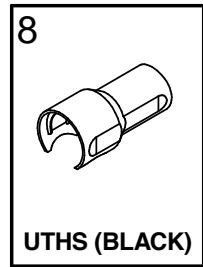

ECLIPSE HEAT
SHIELD

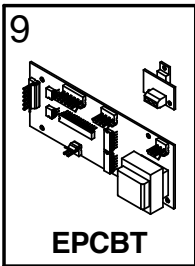

ECLIPSE PCB FOR
HT3C10

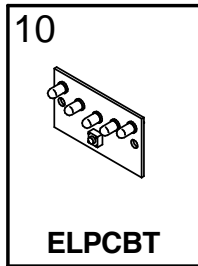

ECLIPSE LIGHT PCB
FOR ALL MODELS

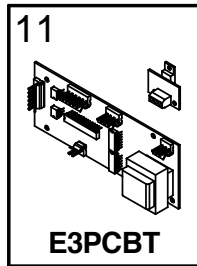

ECLIPSE PCB FOR
HT3C20

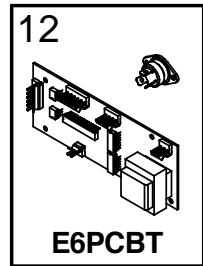

ECLIPSE PCB FOR
HT6C20

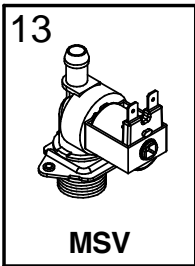

SOLENOID VALVE

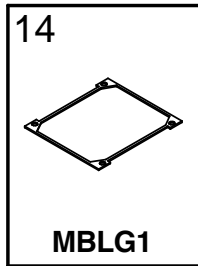

BODY LID GASKET
FOR HT3C10 MODEL

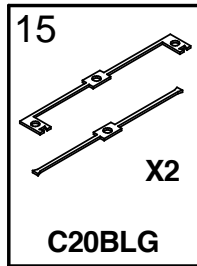

BODY LID GASKET
FOR MODELS
3C20 & 6C20

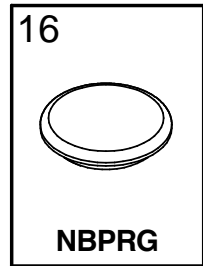

BODY LID GROMMET

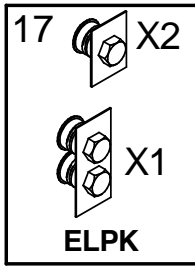

ECLIPSE LEVEL
PROBES KIT

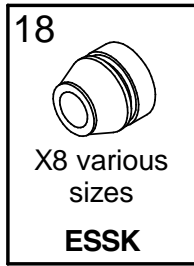

ECLIPSE SILICONE
SEAL KIT

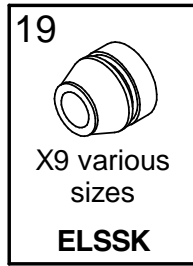

ECLIPSE LARGE
SILICONE SEAL KIT

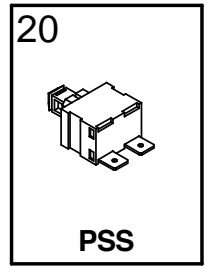

POWER SWITCH

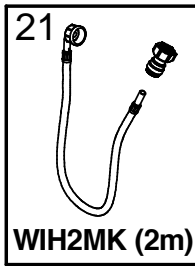

WATER INLET
HOSE

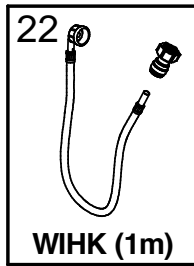

WATER INLET
HOSE

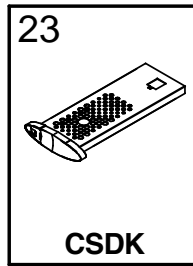

CUP STAND
DRAWER KIT

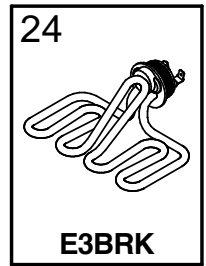

ELEMENT 3kW

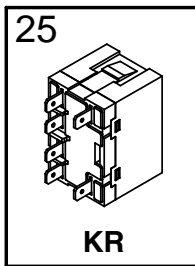

RELAY

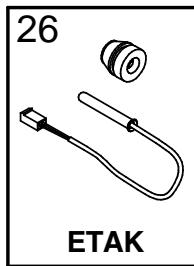

ECLIPSE
THERMISTOR
ASSEMBLY KIT

EXPLODED PARTS VIEW FOR ECLIPSE HT3C10

(To be read in conjunction with the spare parts list)

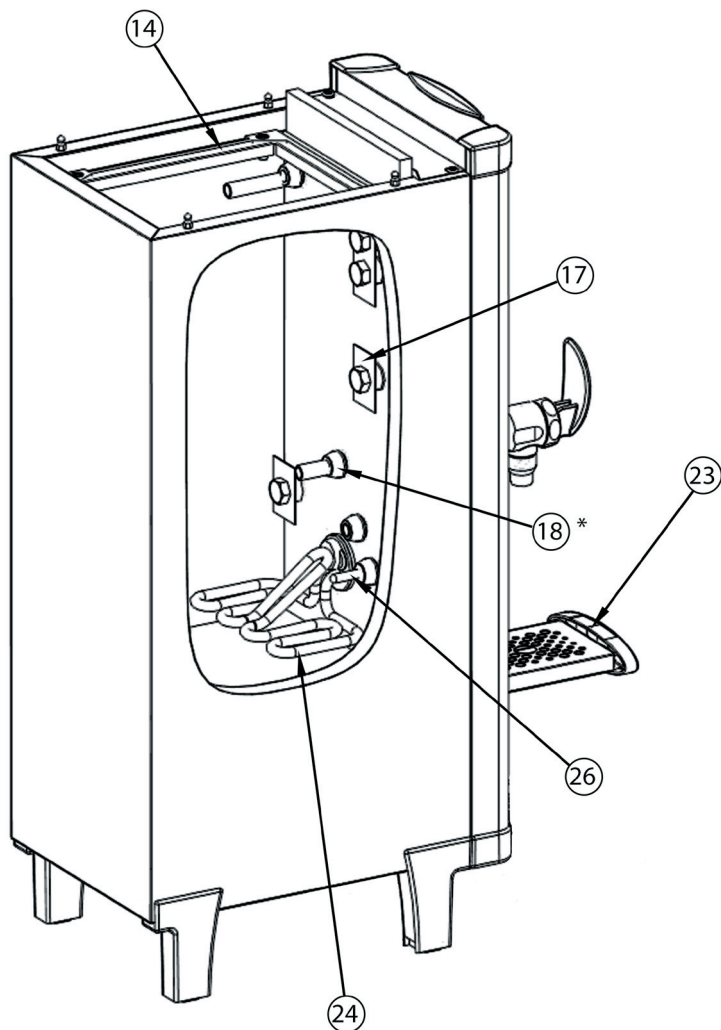

* Complete set of 8 seals (2 sizes)

If parts required are not identified, please contact Calomax Limited

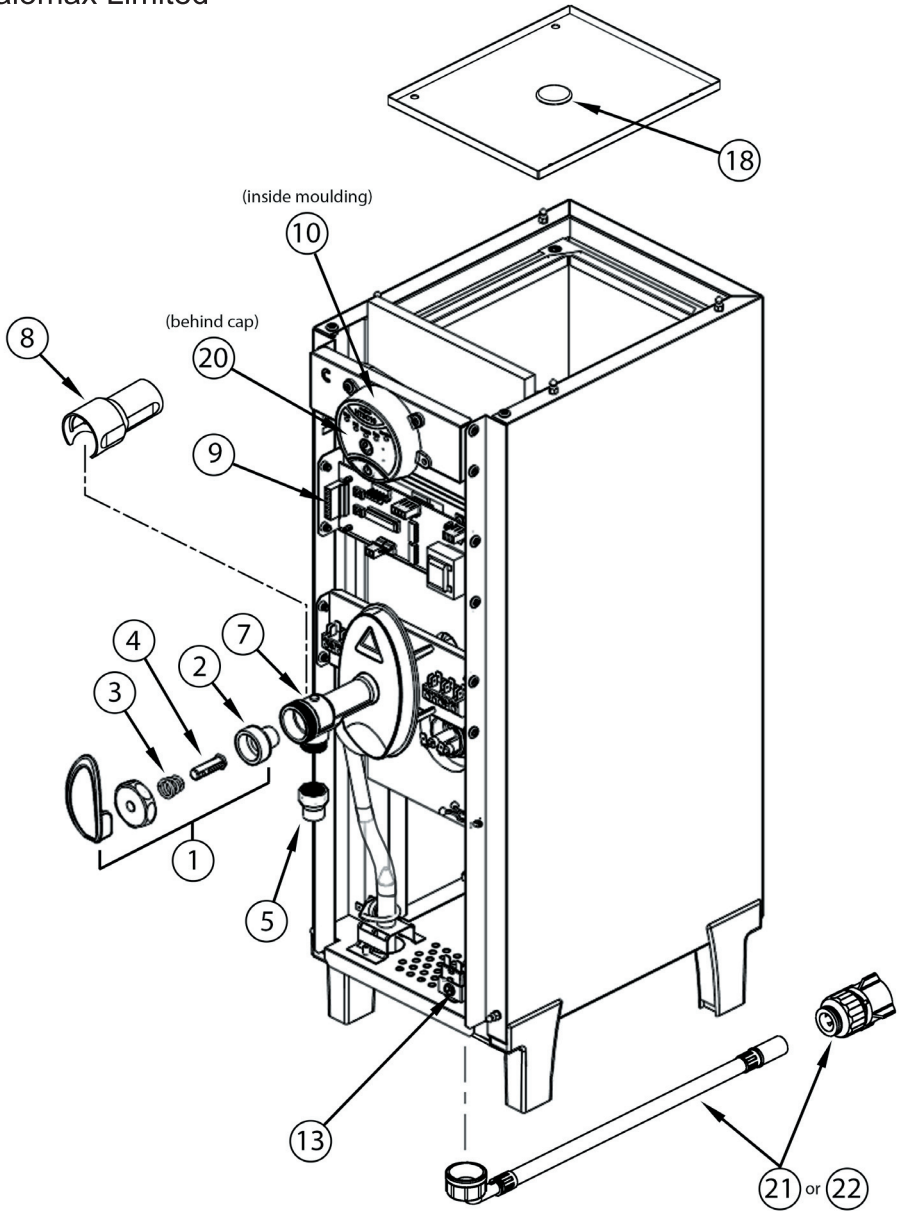

EXPLODED PARTS VIEW FOR ECLIPSE HT3C20

(To be read in conjunction with the spare parts list)

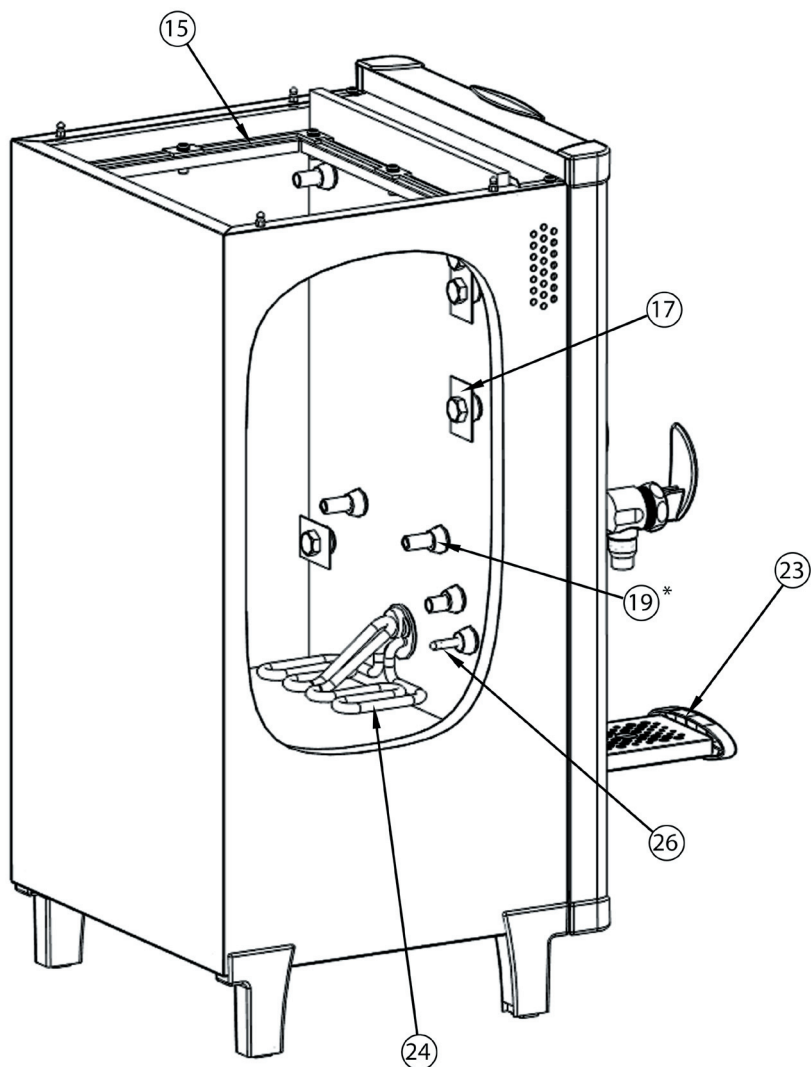

* Complete set of 9 seals (2 sizes)

If parts required are not identified, please contact Calomax Limited

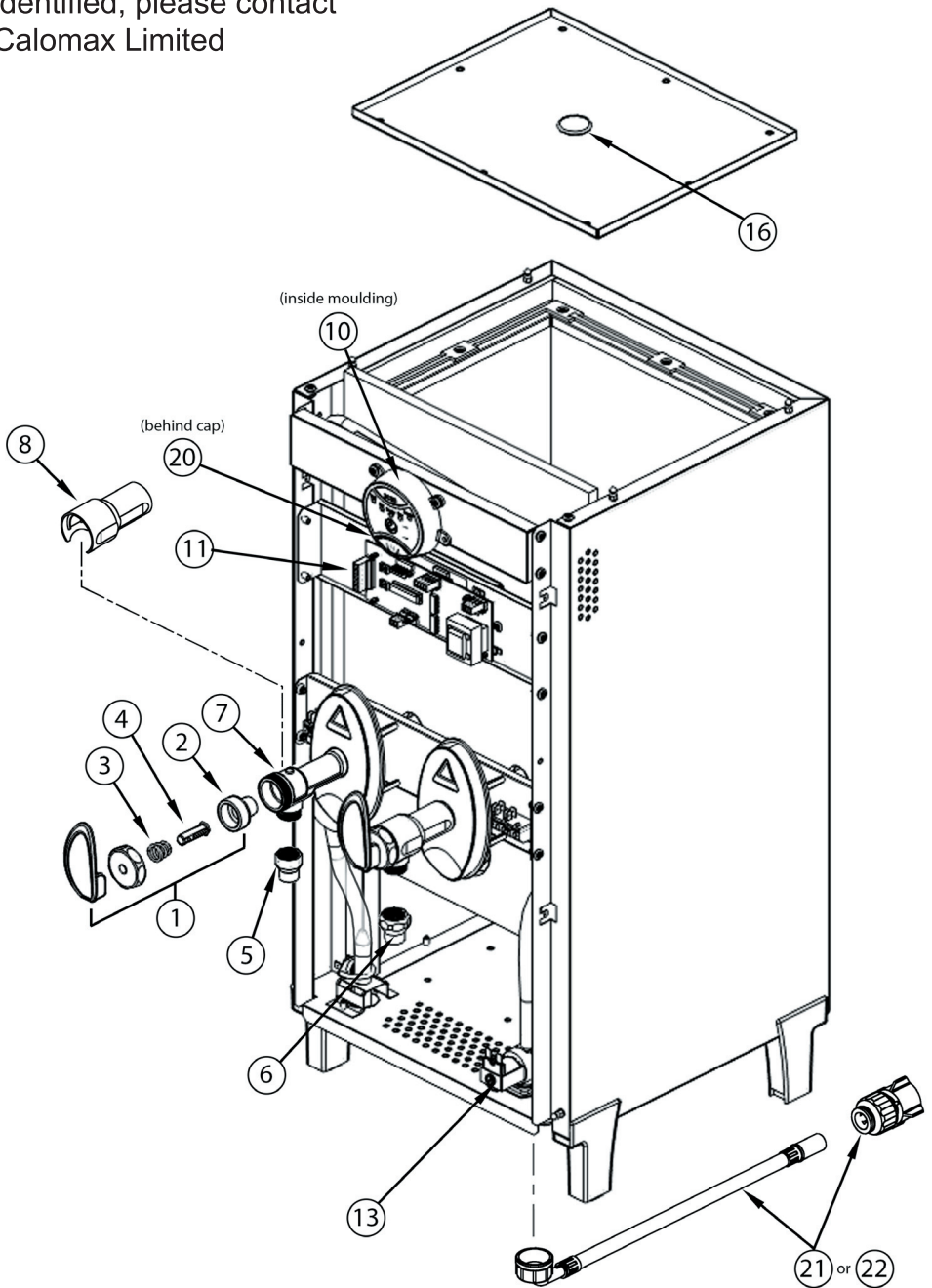

EXPLODED PARTS VIEW FOR ECLIPSE HT6C20

(To be read in conjunction with the spare parts list)

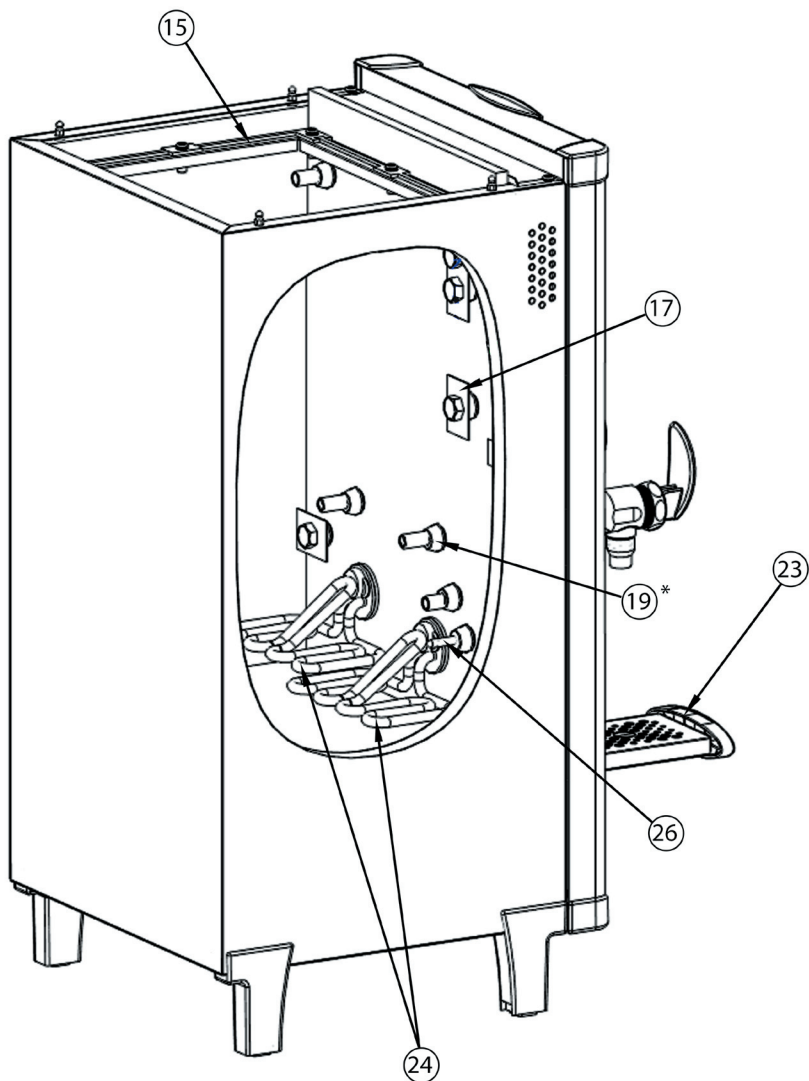

* Complete set of 9 seals (2 sizes)

If parts required are not identified, please contact Calomax Limited

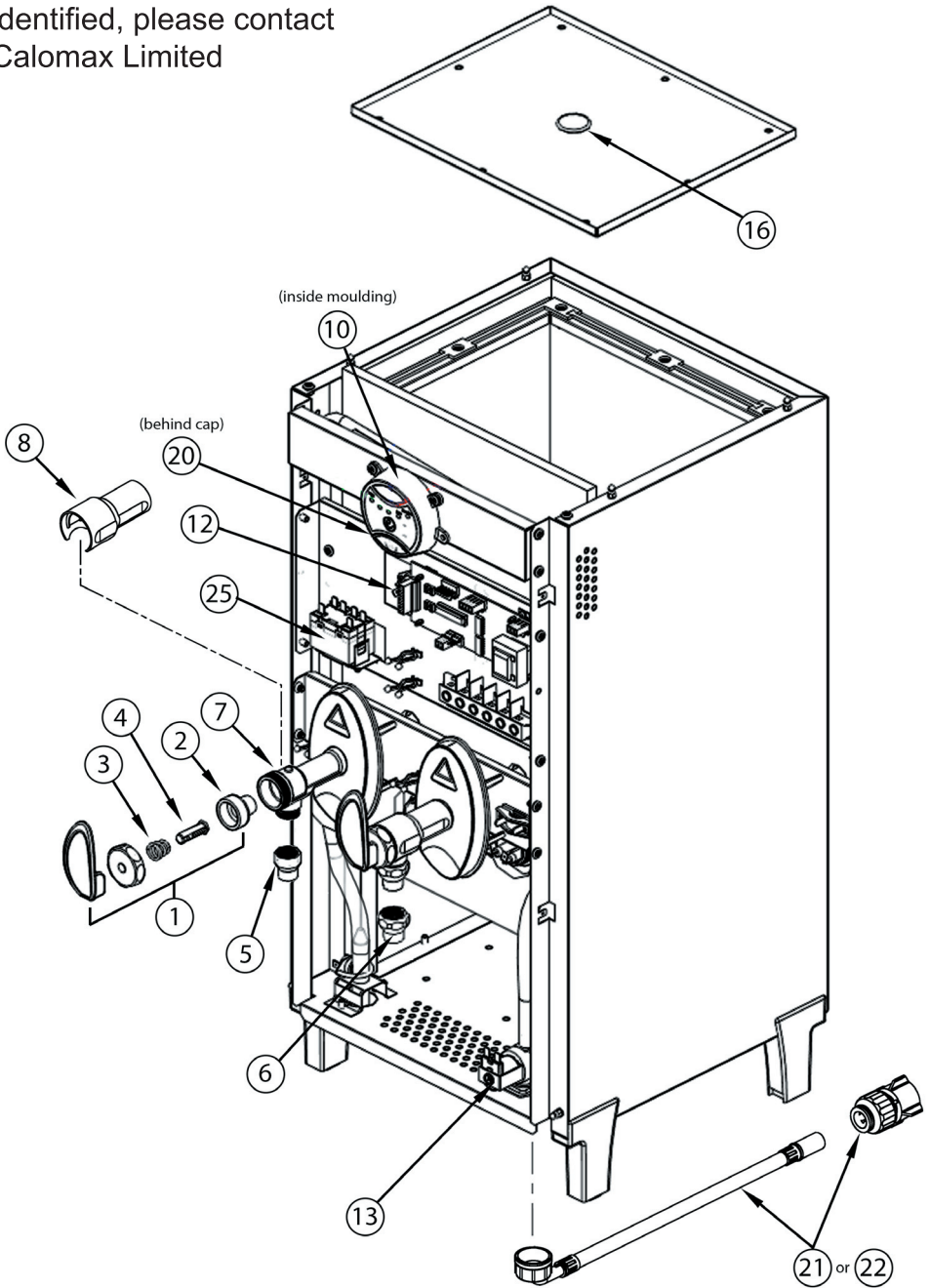

SERVICE INSTRUCTIONS

When the red 'Service' indicator light on the front of the boiler is illuminated (solidly), the machine has been starved of water in excess of 30 minutes and the solenoid valve has been disabled to prevent damage to the solenoid coil through overheat. To re-energise the solenoid, the electrical supply must be switched off and then on again, after first reinstating the water supply.

If the unit requires servicing, the red 'Service' indicator will flash a sequence of light pulses. A 2x or 3x light-pulse generally indicates that the low or normal level probes require de-scaling.

A 4x or 6x light-pulse means the water level has reached the high level sensor and the likelihood is that the normal level sensor requires de-scaling, or the machine has over-filled due to debris trapped in the solenoid valve. The debris can be removed by drawing plenty of water from the dispense tap, causing the solenoid valve to operate and flush out the obstruction. The machine will reset itself once the problem has cleared. If this does not rectify the problem, turn off the water supply and check for debris in the solenoid valve filter. The unit can be used normally while the service indicator is flashing a 4x pulse. For further assistance, contact our service department on 0113 249 6681, e-mail service@calomax.co.uk or find a local service engineer at www.calomax.co.uk

Access to internal components can be gained by the removal of the outer casing lid and front panel. Once the outer casing is removed, access to the Service Area has been gained. This access must be restricted to persons having knowledge and practical experience of the appliance, in particular as far as safety and hygiene are concerned.

DE-SCALE

To gain access to the internals of the water tank, the body lid must be removed. Remove the screws, break the lid gasket seal and lift it clear of the body. A video of this procedure can be viewed under the 'Technical Guides' section on our website.

Note: Whenever the body lid has been removed from the boiler a new lid gasket may be required to ensure a steam-tight joint. Damage to the unit caused by a poor lid seal is not covered by warranty.

Scale deposits should be removed from all internal surfaces, particularly the heating element, thermistor and level sensors by gently tapping or scraping. If the deposits are soft, use a nylon pad and flush out. Abrasive cleaning materials containing scouring powders and detergents must not be used, as such materials can cause taste problems.

Suitable chemical de-scalants must only be used in accordance with the manufacturer's recommendations. This will prevent health and safety issues, taste problems and potential damage to the appliance. All trace of these chemicals must be removed before re-commissioning the unit. Misuse of such chemicals is not covered by the product warranty.

IMPORTANT Before re-commissioning the boiler it is important that all scale and moisture is removed from the level sensors and insulating gaskets to avoid a false signal being transmitted through the scale. Failure to remove this scale and/or moisture will cause the sensor to indicate to the PCB that water is covering the element, whether or not water is present. In this situation the PCB will energise the element causing failure. If in doubt, protect the element by hand filling with water to the level of the draw-off tap before switching on the electrical supply to the boiler.

GENERAL FUNCTION

The printed circuit board (PCB) controls the heating and filling functions of the boiler by monitoring the thermistor and level sensors. The PCB also controls the external light unit to indicate the current state of the boiler. Red and yellow LED'S on the circuit board indicate whether the PCB has energised the element or solenoid respectively.

Should an element fail and need to be replaced, it may be necessary to replace the lid gasket to ensure a reliable steam-tight seal.

Note: the element has a permanent 'Live' feed, and the 'Neutral' is switched. A video showing how to replace an element can be viewed under the 'Technical Guides' section on our website

PRINTED CIRCUIT BOARD REPLACEMENT (PCB).

In the unlikely event of a PCB failing and a replacement being required, full instructions will be supplied. It is important to note however, that the separate Triac PCB must be securely mounted against the copper heat-sink to ensure reliable heat dissipation. Heat transfer compound is also supplied with all replacement circuit boards.

WATER TEMPERATURE

The temperature potentiometer is pre-set at Calomax and will only require adjustment in exceptional circumstances. Contact Calomax for advice.

Water boils at different temperatures depending on barometric pressure. The temperature should not be tuned higher than 98°C, or over boiling may occur during low barometric pressure conditions.

Wiring Schematic for HT3C10 & HT3C20

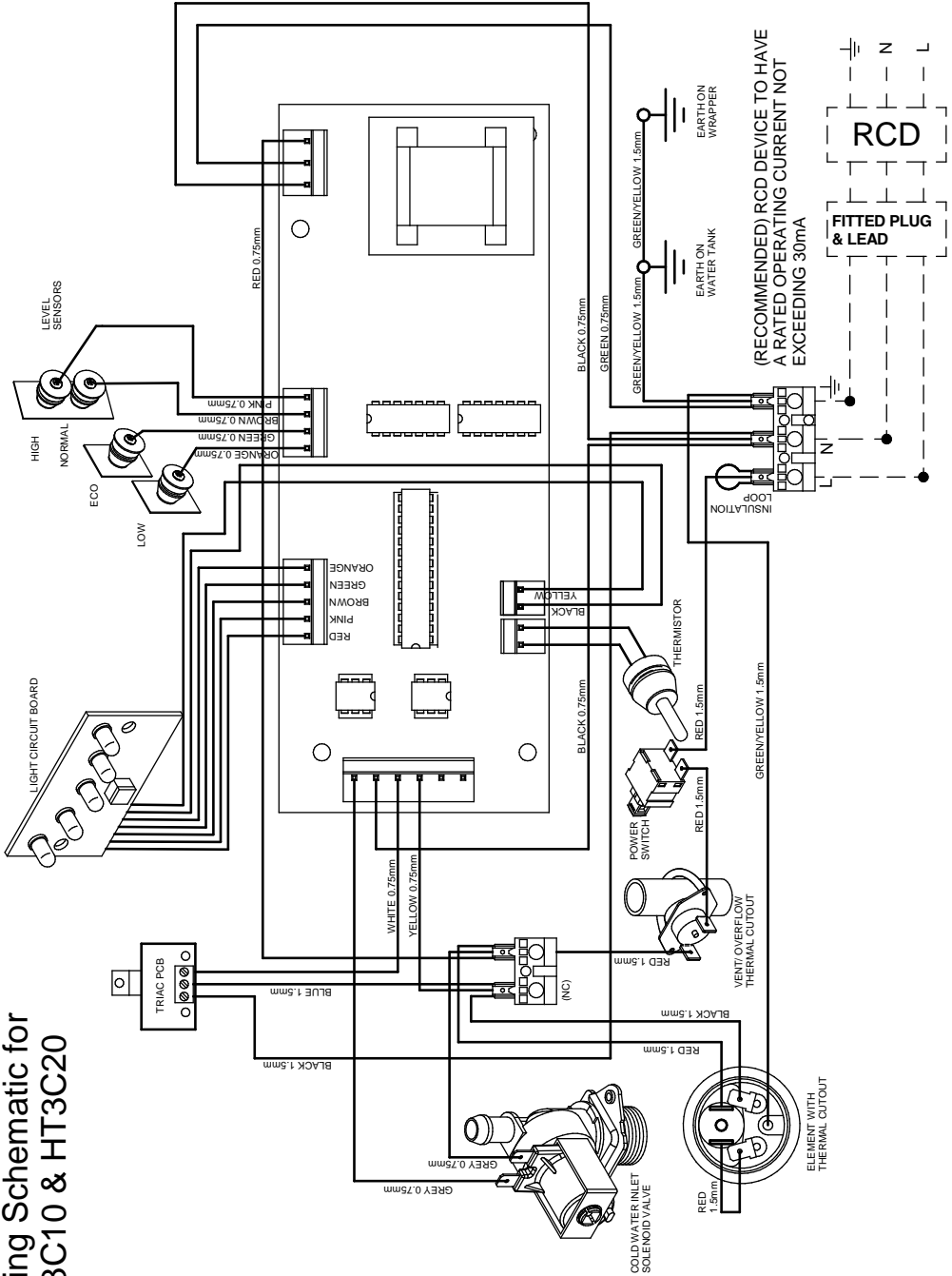

Wiring Schematic for HT6C20

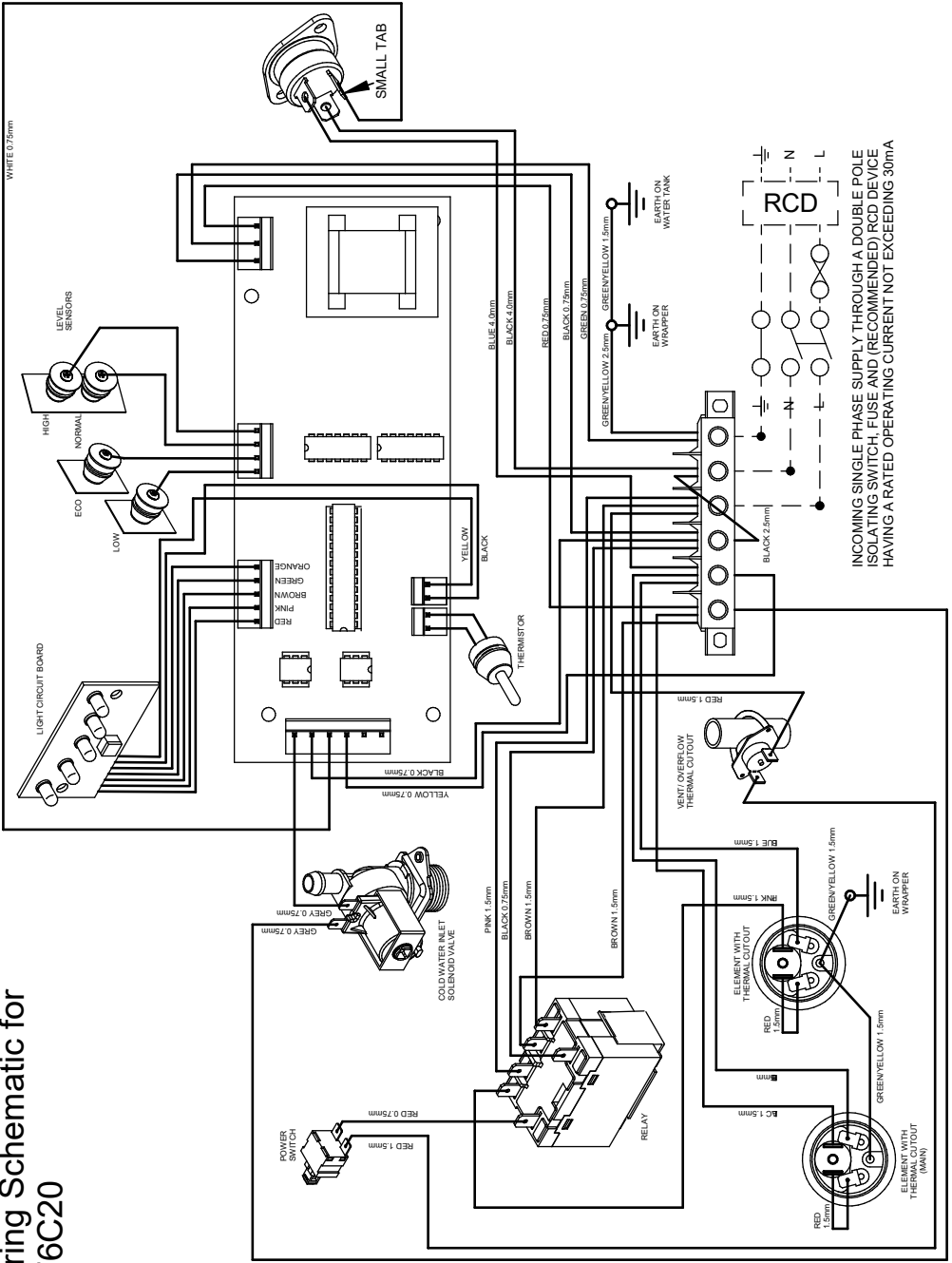

WARRANTY GUARANTEE (UK Mainland customers only)

Calomax have manufactured water boilers in the UK for over 70 years. We are proud of our products and the back-up service we provide

Properly maintained and serviced, a Calomax boiler should last many years and we have no hesitation in providing a 2 year warranty.

Some factors are beyond our control and would invalidate the warranty offered. These include:

- Incorrect installation
- High / Low water pressure
- Incorrect voltage supply
- Accidental damage
- Limescale build-up

The last item can be a particular problem for water dispensing equipment in hard-water areas. All hot water equipment should be serviced and de-scaled by approved organisations on a regular basis to avoid a damaging build-up of limescale.

Although our boilers incorporate scale-inhibitor technology, we recommend that a taste, odour and scale filter should be fitted where appropriate.

Please visit our website www.calomax.co.uk for details of our service partner network and the range of filters and accessories available.

PRODUCT SPECIFICATION

PLEASE FILL IN MODEL & SERIAL NUMBER FOR FUTURE REFERENCE

Model		
Serial Number		
Draw off Capacity	HT3C10 HT3C20 HT6C20	10 Litres 20 Litres 20 Litres
Heat-up Time (First fill to full capacity)	HT3C10 HT3C20 HT6C20	30 Minutes 71 Minutes 38 Minutes
Voltage	HT3C10 HT3C20 HT6C20	220 - 240 V ac 50-60 Hz 220 - 240 V ac 50-60 Hz 220 - 240 V ac 50-60 Hz 25 Amp SINGLE PHASE
Power rating	HT3C10 HT3C20 HT6C20	3kW (MAX) 3kW (MAX) 6kW (MAX)

DIMENSIONS AND WEIGHTS

MODEL	HT3C10	HT3C20	HT6C20
Height (mm)	760	800	800
Depth (mm) *With Drip Tray	530	560	560
Width (mm)	240	370	370
Drip tray clearance (mm)	300	300	300
Working weight (Kg)	30	53	54

Note: All measurements are approximate

PLEASE CONTACT OUR SERVICE DEPARTMENT FOR ASSISTANCE

Calomax Limited, Lupton Avenue, Leeds LS9 7DD

Tel: 0113 249 6681

e-mail: service@calomax.co.uk

