

ECLIPSE HT3C20

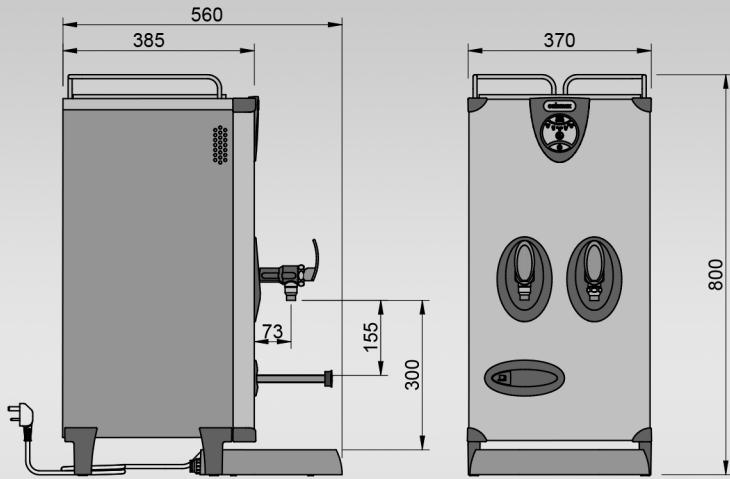

Key Features:

- UK designed and made
- 20L rapid draw off
- Choice of flow rates to ensure suitability for all applications
- Easy install and service features - removable front panel
- Energy-saving "eco" button which reduces the volume of boiling water by 50% at "off peak" times of demand
- SteriTouch Antimicrobial protection in the tap handle and spill tray
- Clear and unambiguous self-diagnostic display panel
- Integral scale-inhibitor technology
- Extended 2-year warranty
- No steam emissions
- 13A plug fitted
- Discrete on/off switch incorporated into moulding
- Competitively priced
- Cool-to-touch stainless steel outer casing
- Integrated pop-out cup tray and cup rail
- Complete with matching spill-tray
- Supplied complete with food grade hose
- Counter-top securing clamps available as an optional extra



SIZE	REF	CASING	RATING	CAPACITY (including initial draw-off)	DIMENSIONS (W x D x H)
20 LITRE	HT3C20	STAINLESS STEEL	3kW	40 LITRES PER HOUR	370 x 560 x 800 (including drip tray)