

**UNDERCOUNTER DISHWASHERS
FP SERIES**



HOBART UK,
SOUTHGATE WAY,
ORTON SOUTHGATE,
PETERBOROUGH.
PE2 6GN
0844 888 7777

www.hobartuk.com

Undercounter Dishwasher with Vaporinse

FP-10C

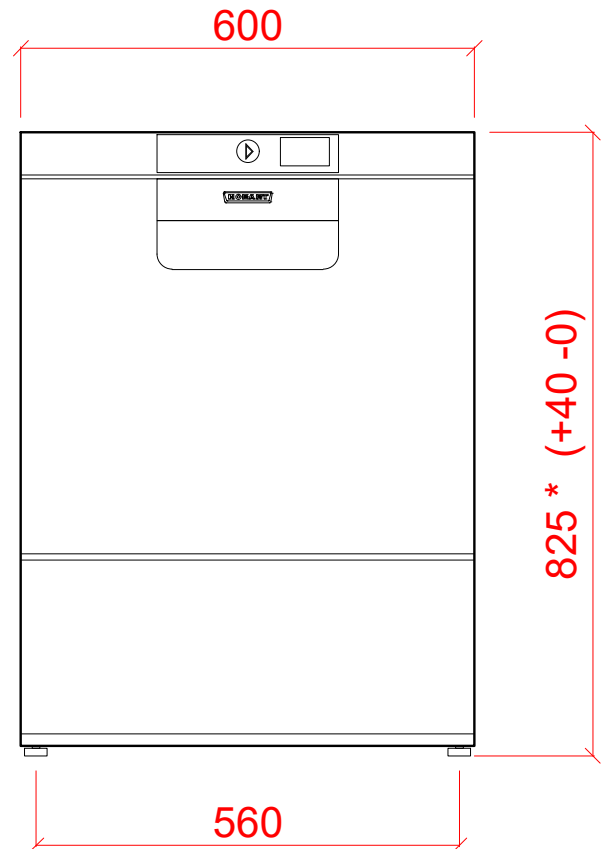
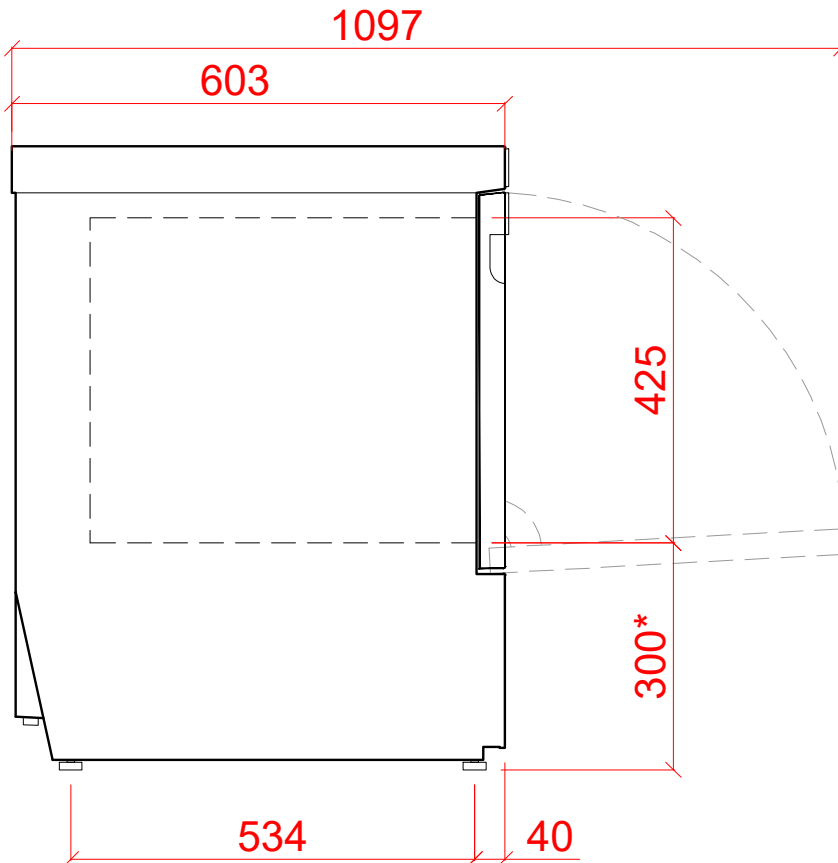
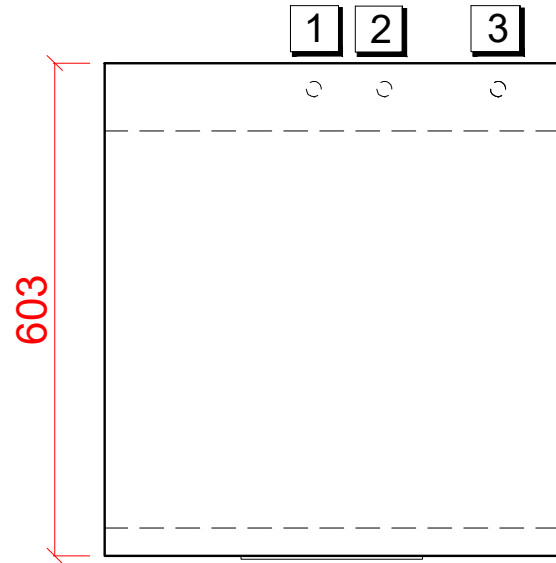

1 Water

22mm CONNECTION VIA 2 METRE FLEXIBLE HOSE, FEMALE TERMINATION.

WATER SUPPLY 10°C TO 60°C (0° TO 3° CLARK MAX) @ 0.6 TO 6.0 BAR MAX. INITIAL TANK FILL 10.8 LITRES.

RINSE WATER USAGE 0.8 LITRES PER CYCLE. MAX USAGE 36 LITRES PER HOUR.

OUR MACHINES ARE SUPPLIED WITH CLASS 'AB' AIR GAP AS STANDARD.

2 Drain

DRAIN - 2 METRE FLEXIBLE HOSE TO A 40 mm TRAPPED STANDPIPE 800mm MAX A.F.F.L.

FLOW RATE 30 LITRES PER MINUTE.

Other Services

RINSE AGENT HOSE - 2.5 METRE FLEXIBLE.
DETERGENT HOSE - 2.5 METRE FLEXIBLE.

3 Electric

6.7kW 400/50/3 + N + E FUSED AT 3 x 25amps
MACHINE SUPPLIED WITH 2.5 METERS OF CABLE (3 ph).

CONFIGURABLE TO:

4.7kW 230/50/1 FUSED AT 25amps OR
3.7kW 230/50/1 FUSED AT 20amps (25) OR
3.3kW 230/50/1 FUSED AT 16amps (25)

Notes

APPROX WEIGHTS:
EMPTY: 65kg's WITH WATER: 87kg's
* = + 40mm

PLOT SCALE: 1:10

RIGHT TO MAKE NECESSARY CHANGES IS RESERVED