

**UNDERCOUNTER DISHWASHERS  
FP SERIES**



**HOBART UK,**  
SOUTHGATE WAY,  
ORTON SOUTHGATE,  
PETERBOROUGH.  
PE2 6GN  
0844 888 7777

www.hobartuk.com

**Undercounter Dishwasher with Thermal Disinfection and Built-In Softener**

**CareS-10C**

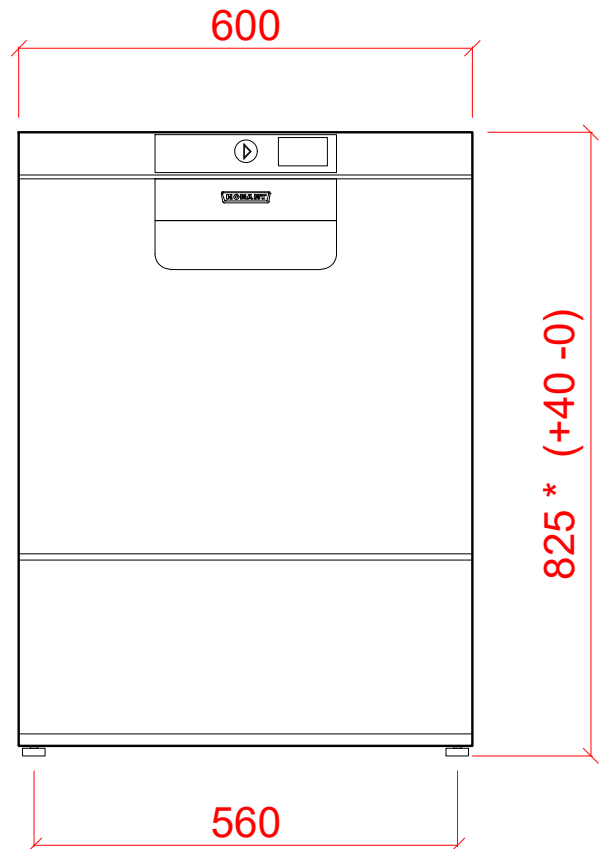
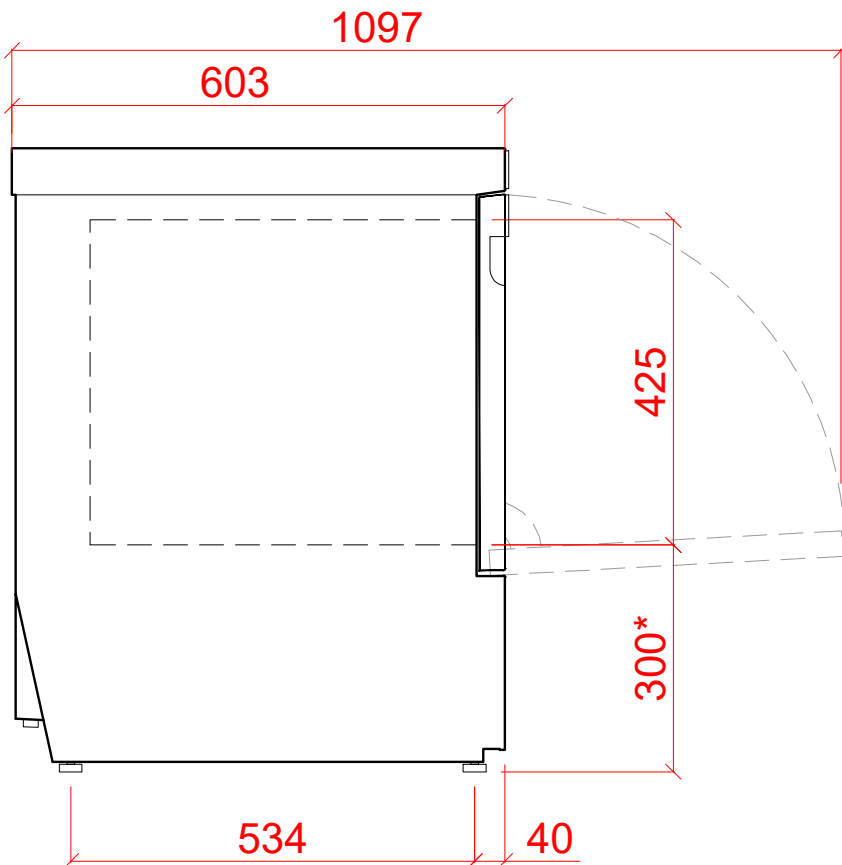

**1 Water**

22mm CONNECTION VIA 2 METRE FLEXIBLE HOSE, FEMALE TERMINATION.

WATER SUPPLY 10°C TO 60°C @ 0.6 TO 6.0 BAR MAX. INITIAL TANK FILL 10.8 LITRES.

RINSE WATER USAGE 3.5 LITRES PER CYCLE. MAX USAGE 20 CYCLES PER HOUR.

OUR MACHINES ARE SUPPLIED WITH CLASS 'AB' AIR GAP AS STANDARD.

**2 Drain**

DRAIN - 2 METRE FLEXIBLE HOSE TO A 40 mm TRAPPED STANDPIPE 800mm MAX A.F.F.L.

FLOW RATE 30 LITRES PER MINUTE.

**Other Services**

RINSE AGENT HOSE - 2.5 METRE FLEXIBLE. DETERGENT HOSE - 2.5 METRE FLEXIBLE.

**3 Electric**

6.8kW 400/50/3 + N + E FUSED AT 3 x 16amps. MACHINE SUPPLIED WITH 2.5 METRES OF CABLE (3 PHASE).

**CONFIGURABLE TO:**  
4.7kW 230/50/1 FUSED AT 25amps

**Notes**

APPROX WEIGHTS:  
EMPTY: 65kg's WITH WATER: 87kg's  
\* = + 40mm

**PLOT SCALE: 1:10**

RIGHT TO MAKE NECESSARY CHANGES IS RESERVED