

**UNDERCOUNTER DISHWASHERS  
FX SERIES**



**HOBART UK,**  
SOUTHGATE WAY,  
ORTON SOUTHGATE,  
PETERBOROUGH.  
PE2 6GN  
0844 888 7777

www.hobartuk.com

**Undercounter Dishwasher with Large Wash Chamber and In Built Softener**

**FXLS-10C**

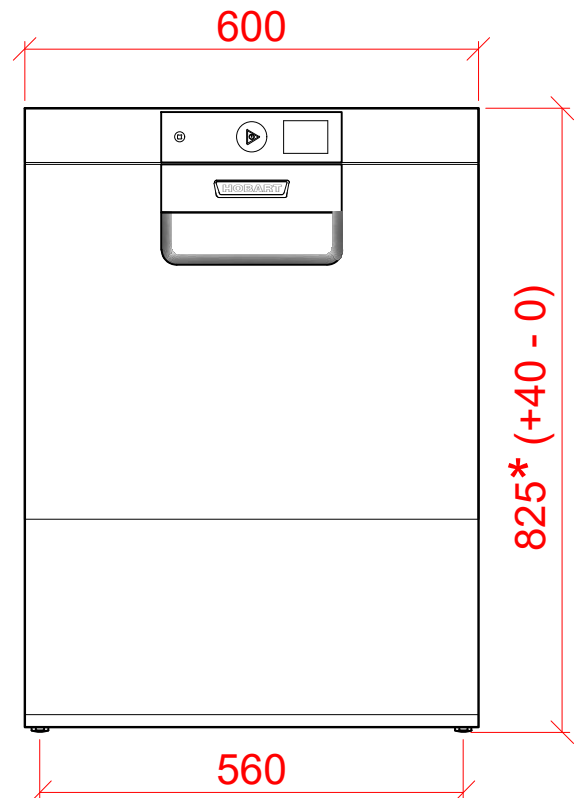
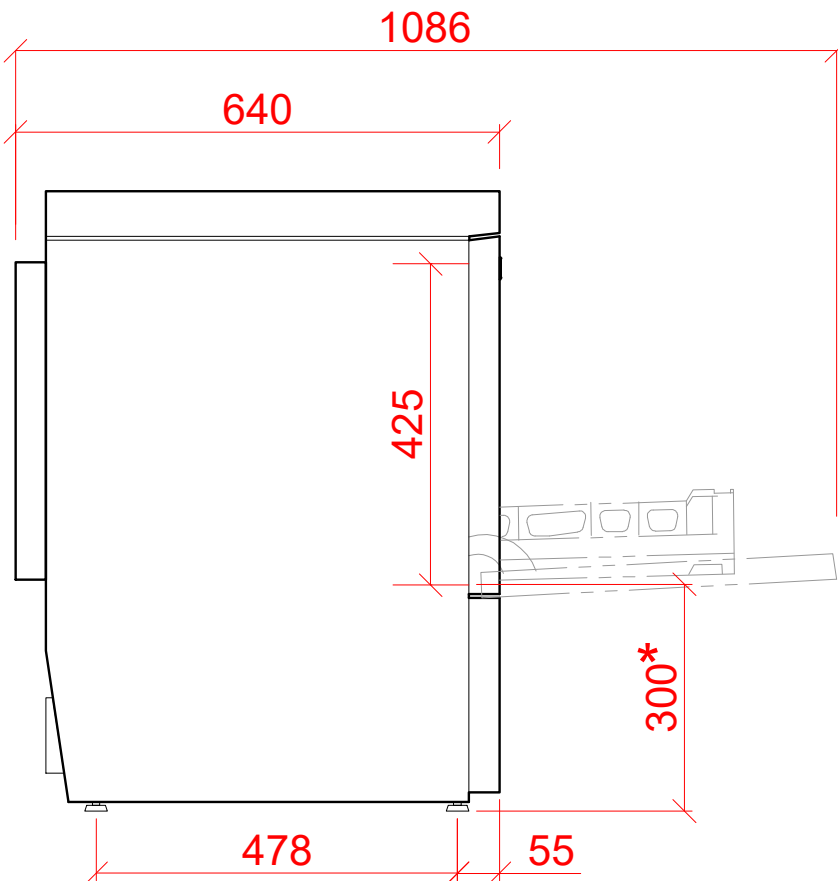
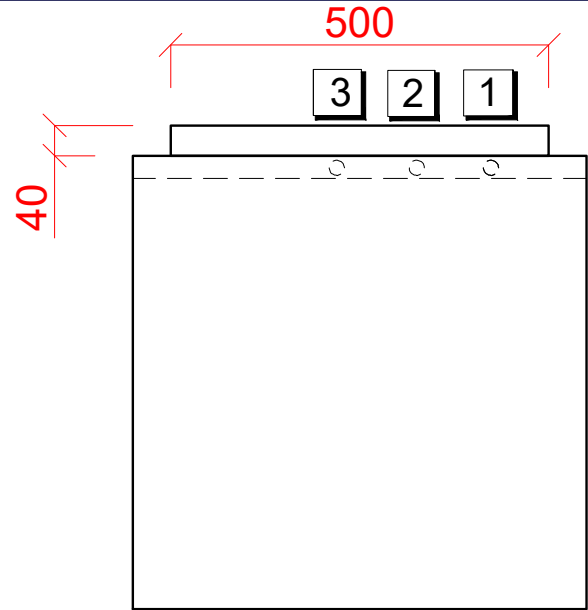

**1 Water**

22mm CONNECTION VIA 2 METRE FLEXIBLE HOSE, FEMALE TERMINATION.

WATER SUPPLY 10°C TO 60°C (0°C-3°C) @ 0.6 TO 6.0 BAR MAX. INITIAL TANK FILL 10.8 LITRES.

RINSE WATER USAGE 1.8 LITRES PER CYCLE. MAX USAGE 72 LITRES PER HOUR.

OUR MACHINES ARE SUPPLIED WITH CLASS 'AB' AIR GAP AS STANDARD.

**2 Drain**

DRAIN - 2 METRE FLEXIBLE HOSE TO A 40 mm TRAPPED STANDPIPE 800mm MAX A.F.F.L.

FLOW RATE 30 LITRES PER MINUTE.

**Other Services**

RINSE AGENT HOSE - 2.5 METRE FLEXIBLE.  
DETERGENT HOSE - 2.5 METRE FLEXIBLE.

**3 Electric**

6.7kW 400/50/3 + N + E FUSED AT 3 x 13amps. MACHINE SUPPLIED WITH 2.5 METERS OF CABLE (3 PHASE).

**CONFIGURABLE TO:**  
4.7kW 230/50/1 FUSED AT 25amps OR  
3.7kW 230/50/1 FUSED AT 20amps (25) OR  
2.6kW 230/50/1 FUSED AT 13amps (25)

**Notes**

APPROX WEIGHTS:  
EMPTY: 65kg's WITH WATER: 87kg's  
\* = + 40mm

**PLOT SCALE: 1:10**

RIGHT TO MAKE NECESSARY CHANGES IS RESERVED