

CATER-WASH

18kg Washing Machine - CW8518

User Manual &
Installation Instructions

To avoid risk of accidents or damage to the appliance, it is essential to read these instructions before it is installed and used for the first time.

Caterkwik

The Lakeland Catering Centre
Ulverston
Cumbria
LA12 7QQ

e: info@caterwash.com

t: 01229 480001

w: www.caterwash.com



WASHER SAFETY	3
Proper Installation	5
When Not in Use	5
OPERATION REQUIREMENTS	6
Location of Your Washer.....	6
Electrical Requirements.....	6
Water Supply Requirements.....	7
Drain Requirements	7
INSTALLATION INSTRUCTIONS	8
Before You Begin.....	8
Tools Required.....	8
Additional Parts Required	9
Parts Supplied.....	9
Dimensions	9
Unpacking the Washer.....	10
Installing the Washer.....	11
WASHER USE	14
Control Panel.....	14
Features	21
Loading and Using the Washer.....	24
WASHER MAINTENANCE	25
Cleaning	25
Moving and Storage.....	29
BEFORE YOU CALL FOR SERVICE ..	30
Error Codes	37
MAINTENANCE	38

WASHER SAFETY

YOUR SAFETY AND THE SAFETY OF OTHERS ARE VERY IMPORTANT

To prevent injury to the user or other people and property damage, the instructions shown here must be followed. Incorrect operation due to ignoring these instructions may cause harm or damage, including death.

The level of risk is shown by the following indications.



This symbol indicates the possibility of death or serious injury.



This symbol indicates the possibility of injury or damage to property.



This symbol indicates the possibility of dangerous voltage constituting a risk of electrical shock is present that could result in death or serious injury.

This appliance is not intended for use by persons (including children) with reduced physical, sensory or mental capabilities, or lack of experience and knowledge, unless they have been given supervision or instruction concerning use of the appliance by a person responsible for their safety. Children should be supervised to ensure that they do not play with the appliance.

If the supply cord is damaged, it must be replaced by the manufacturer's service agent or similarly qualified persons in order to avoid a hazard.

The maximum inlet water pressure: **0.03MPa**

The minimum inlet water pressure: **1MPa**

The maximum mass of dry cloth is: **18Kg**.

IMPORTANT SAFETY INSTRUCTIONS

WARNING

To reduce the risk of death, fire, explosion, electric shock, or injury to persons when using your appliance, follow basic precautions, including the following:

- Read the instruction manual before using the appliance.
- **DO NOT** wash or dry items that have been previously cleaned in, washed in, soaked in or spotted with gasoline, dry-cleaning solvents, or other flammable or explosive substances, as they give off vapors that could ignite or explode.
- **DO NOT** add gasoline, dry-cleaning solvents, or other flammable or explosive substances to the wash water. These substances give off vapors that could ignite or explode.
- Under certain conditions, hydrogen gas may be produced in a hot-water system that has not been used for 2 weeks or more. **HYDROGEN GAS IS EXPLOSIVE.** If the hot water system has not been used for such a period, before using a washing machine, turn on all hot-water faucets and let the water flow from each for several minutes. This will release any accumulated hydrogen gas. As the gas is flammable, **DO NOT** smoke or use an open flame during this time.
- **DO NOT** allow children to play on or in this appliance. Close supervision of children is necessary when this appliance is used near children. Before the washer is removed from service or discarded, remove the door or lid. Failure to follow these instructions may result in death or injury to persons.
- **DO NOT** reach into the appliance if the drum or other components are moving to prevent accidental entanglement.
- **DO NOT** install or store this appliance where it will be exposed to the weather.
- **DO NOT** tamper with controls, repair or replace any part of this appliance or attempt any servicing unless specifically recommended in the user maintenance instructions or in published user repair instructions that you understand and have the skills to carry out.
- Keep the area around your appliance clean and dry to reduce the possibility of slipping.
- **DO NOT** operate this appliance if it is damaged, malfunctioning, partially disassembled, or has missing or broken parts including a damaged cord or plug.
- Unplug the appliance or turn off the circuit breaker before servicing. Pressing the Power button **DOES NOT** disconnect power
- See “Electrical Requirements” located in the Installation Instructions for grounding instructions. This appliance is not intended for use by persons (including children) with reduced physical, sensory or mental capabilities, or lack of experience and knowledge, unless they have been given supervision or instruction concerning use of the appliance by a person responsible for their safety. Children should be supervised to ensure that they do not play with appliance.

- If the supply cord is damaged, it must be replaced by the manufacture, its service agent or similarly qualified persons in order to avoid a hazard.
- The new hose-sets bought from the retailer where the product was purchased are to be used and that old hose-sets should not be reused.
- This appliance is for indoor use only

PROPER INSTALLATION

- This washer must be properly installed and located in accordance with the Installation Instructions before it is used. Ensure the cold water hose is connected to the "C" valve.
- Install or store where it will not be exposed to temperatures below freezing or exposed to the weather which could cause permanent damage and invalidate the warranty
Properly ground washer to conform with all governing codes and ordinances. Follow details in installation instructions.

WARNING

Electrical Shock Hazard



- Plug into a grounded 3 prong outlet.
- Do not remove the ground prong.
- Do not use an adapter
- Do not use an extension cord.
- Failure to do so can result in death, fire or electrical shock.

WHEN NOT IN USE

Turn off water faucets to minimise leakage if a break or rupture should occur
Check the condition of the fill hoses; We recommend changing the hoses every 5 years.

SAVE THESE INSTRUCTIONS

THIS APPLIANCE IS FOR HOUSEHOLD USE ONLY

OPERATION REQUIREMENTS

LOCATION OF YOUR WASHER

DO NOT INSTALL THE WASHER:

1. In an area exposed to dripping water or outside weather conditions. The ambient temperature should never be below 60°F (15.6°C) for proper washer operation.
2. In an area where it will come in contact with curtains or drapes.
3. On carpet. The floor **MUST** be a hard surface with a maximum slope of 1/2" per foot (1.27 cm per 30 cm). To make sure the washer does not vibrate or move, you may have to reinforce the floor

NOTE: If floor is in poor condition, use 3/4" impregnated plywood sheet solidly attached to the existing floor covering.

IMPORTANT: MINIMUM INSTALLATION CLEARANCES

- When installed in alcove: Top and Sides = 0" (0 cm), Back = 3" (76 cm)
- When installed in closet: Top and Sides = 0" (0 cm), Front = 2" (5 cm), Back = 3" (7.6 cm)
- Closet door ventilation openings required: 2 louvers each 60 square in.(387 cm), located 3" (7.6 cm) from top and bottom of door

ELECTRICAL REQUIREMENTS

Read these instructions carefully.

WARNING

TO REDUCE THE RISK OF FIRE, ELECTRICAL SHOCK AND PERSONAL INJURY:

- **DO NOT USE AN EXTENSION CORD OR AN ADAPTER PLUG WITH THIS APPLIANCE. =The washer must be electrically grounded in accordance with local codes and ordinances.**

CIRCUIT - Individual, properly polarized and grounded 13-amp branch circuit fused with 13-amp time -delay fuse or circuit breaker

POWER SUPPLY - 2-wire with ground, 220V-240V, single-phase, 50Hz, alternating current.

OUTLET RECEPTACLE - Properly grounded receptacle located so the power supply cord is accessible when the washer is in an installed position.

GROUNDING REQUIREMENTS

Improper connection of the equipment grounding conductor can result in a risk of electrical shock. Check with an electrician if you are in doubt as to whether the appliance is properly grounded.

1. The washer **MUST** be grounded. In the event of malfunction or breakdown, grounding will reduce the risk of electrical shock by providing a path of least resistance for electrical current.
2. Since your washer is equipped with a power supply cord having an equipment-grounding conductor and a grounding plug, the plug **MUST be plugged into an appropriate, copper-wired receptacle** that is properly installed and grounded in accordance with all local codes. If in doubt, call a licensed electrician.
3. **DO NOT** cut off or alter the grounding prong on the power supply cord. In situations where a two-slot receptacle is present, it is the owner's responsibility to have a licensed electrician replace it with a **properly grounded** grounding-type receptacle.

WATER SUPPLY REQUIREMENTS

Cold water faucet **MUST** be installed within 42" (107 cm) of your washer's water inlet. The faucet **MUST** be $\frac{3}{4}$ " (1.9 cm) BSP so the inlet hose can be connected. Water pressure **MUST** be between 10 and 120 psi. Your water department can advise you of your water pressure.

DRAIN REQUIREMENTS

1. Drain capable of eliminating 64.3 L per minute.
2. A standpipe diameter of $1\frac{1}{4}$ " (3.18 cm) minimum.
3. The standpipe height above the floor should be:

Minimum height: 24" (61 cm)

Maximum height: 47.24" (120 cm)

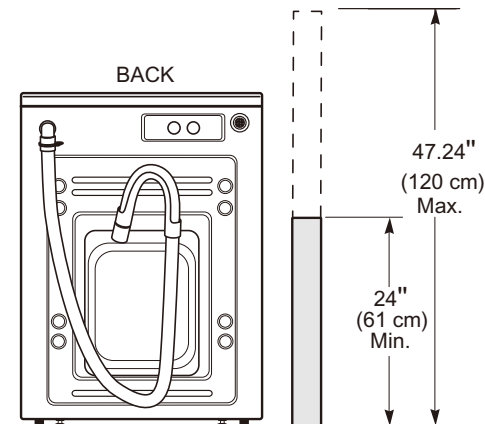

INSTALLATION INSTRUCTIONS

BEFORE YOU BEGIN

Read these instructions completely and carefully.

- **IMPORTANT** - Save these instructions.
- **IMPORTANT** - Observe all governing codes and ordinances.
- **Note to Installer** - Be sure to leave these instructions with the user.
- **Note to User** - Keep these instructions for future reference.
- **Skill level** - Installation of this appliance requires basic mechanical and electrical skills.
- **Completion time** - 1-3 hours
- Proper installation is the responsibility of the installer.
- Product failure due to improper installation is not covered under the Warranty.

FOR YOUR SAFETY:



WARNING

- This appliance must be properly grounded and installed as described in these Installation Instructions.
- Do not install or store the appliance in an area where it will be exposed to water/ weather. See the Location of Your Washer section.
- **NOTE:** This appliance must be properly grounded, and electrical service to the washer.

TOOLS REQUIRED

- Adjustable wrench or 1/2 " socket with ratchet
- Adjustable wrench or 9/16 " open-end wrench
- Channel-lock adjustable pliers
- Spirit level

ADDITIONAL PARTS REQUIRED

Water Hose
(For COLD water faucet)



CKP0142

PARTS SUPPLIED

Cable Tie



Drain Hose Guide

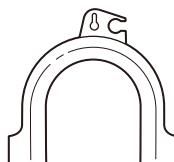

DIMENSIONS

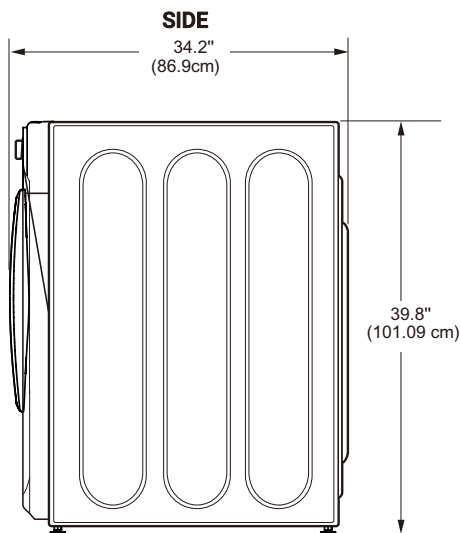
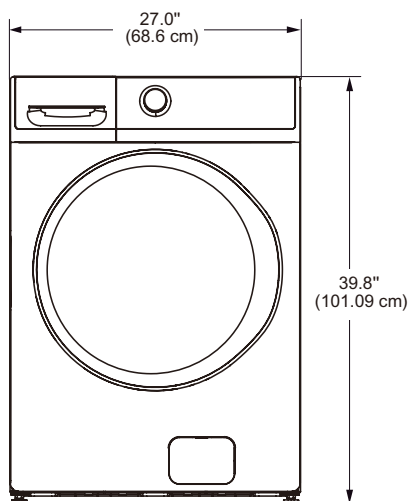

***NOTE:** With pedestal*, 52.6"
Stacked, 84"

*Special Order

UNPACKING THE WASHER

WARNING:

- Recycle or destroy the carton and plastic bags after the washer is unpacked. Make materials inaccessible to children. Children might use them for play. Cartons covered with rugs, bedspreads or plastic sheets can become airtight chambers causing suffocation.

1. Cut and remove the top and bottom packaging straps.
2. While it is in the carton, carefully lay the washer on its side. DO NOT lay the washer on its front or back.
3. Turn down the bottom flaps-remove all base packaging, including the cardboard, Styrofoam base and styrofoam tub support (inserted in centre base)

NOTE: If you are installing a pedestal, proceed to the installation instructions that come with the pedestal.

4. Carefully return the washer to an upright position and remove the carton.
5. Carefully move the washer to within 4 feet (122 cm) of the final location.
6. Remove the following from the back side of the washer:

4 bolts

4 plastic spacers (including rubber grommets) 4
power cord retainers

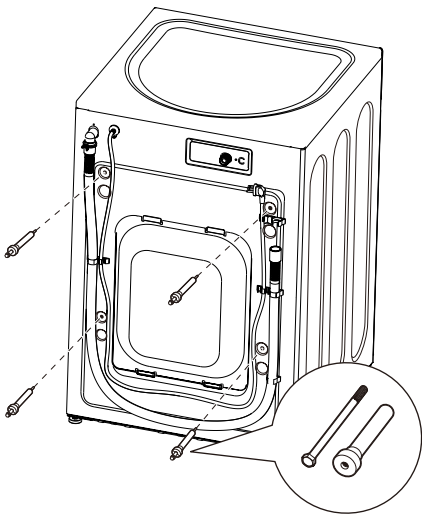

IMPORTANT: Failure to remove the shipping bolts* can cause the washer to become severely unbalanced.

Save all bolts for future use.

*Any damages from failure to remove the shipping bolts are not covered by the warranty.

NOTE: If you must transport the washer at a later date, you must reinstall the shipping support hardware to prevent shipping damage. Keep the hardware in the plastic bag provided.

INSTALLING THE WASHER

1. Run some water from the cold tap to flush the water lines and remove particles that might clog up the inlet hose.
2. Ensure there is a rubber washer in the hoses. Reinstall the rubber washer into the hose fitting if it has fallen out during shipment. Carefully connect inlet hose to the inside "C" outlet of the water valve. Tighten by hand; then tighten another $\frac{2}{3}$ turn with pliers.

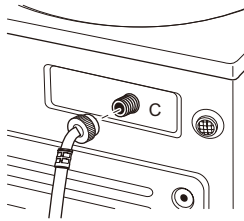

Do not cross thread or over-tighten these connections.

3. Install the screen washers by inserting them into the free ends of the inlet hoses with protruded side facing the faucet.
4. Connect the inlet hose ends to the COLD water faucets tightly by hand, then tighten another $\frac{2}{3}$ turn with pliers. Turn the water on and check for leaks.



5. Carefully move the washer to its final location. Gently rock the washer into position ensuring inlet hoses do not become kinked. It is important not to damage the rubber leveling legs when moving your washer to its final location. Damaged legs can increase washer vibration. It may be helpful to spray window cleaner on the floor to help move your washer into its final position.

NOTE: To reduce vibration, ensure that all four rubber leveling legs are in contact with the floor. Push and pull on the back right and then back left of your washer.

NOTE: If you must transport the washer at a later date, you must reinstall the shipping support hardware to prevent shipping damage. Keep the hardware in the plastic bag provided.

Washer Safety
Operation Requirements
Installation Instructions
Washer Use
Washer Care
Troubleshooting

NOTE: Do not use the dispenser drawer or door to lift the washer.

6. With the washer in its final position, place a spirit level on top of the washer to ensure it is level.

(if the washer is installed under a counter, the washer should not be able to rock).

Adjust the front leveling legs up or down to ensure the washer is resting solid. Turn the lock nuts on each leg up towards the base of the washer and snug with a wrench.

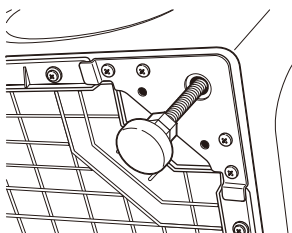

NOTE: Keep the leg extension at a minimum to prevent excessive vibration.

The more the legs are extended, the greater the machine will vibrate.

If the floor is not level or is damaged, you may have to extend the rear leveling legs.

7. Attach the U-shaped hose guide to the end of the drain hose. Place the hose in a laundry tub or standpipe and secure it with the cable tie provided in the enclosure package.

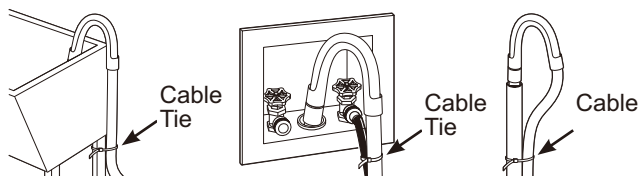

NOTE: Placing the drain hose too far down the drain pipe can cause a siphoning action. No more than 7 inch (177.8 cm) of hose should be in the drain pipe. There must be an air gap around the drain hose. A snug fit can also cause a siphoning action.

8. Plug the power cord into a grounded outlet.

NOTE: Check to be sure the power is off at the circuit breaker/fuse box before plugging the power cord into an outlet.

9. Turn on the power at the circuit breaker/fuse box.

10. Read the rest of this Owner's Manual. It contains valuable and helpful information that will save you time and money.

11. **Before starting the washer, check to make sure:**

- Main power is turned on.
- The washer is plugged in.

- The water is turned on.
- The unit is level and all four leveling legs are firmly in the floor.
- The shipping support hardware is removed and saved.
- The drain hose is properly tied up.

12. Run the washer through a complete cycle.

13. If your washer does not operate, please review the 'Before You Call For Service' section before calling for service.

14. Place these instructions in a location near the washer for future reference.

WASHER USE

CONTROL PANEL

Model: **CW8518**

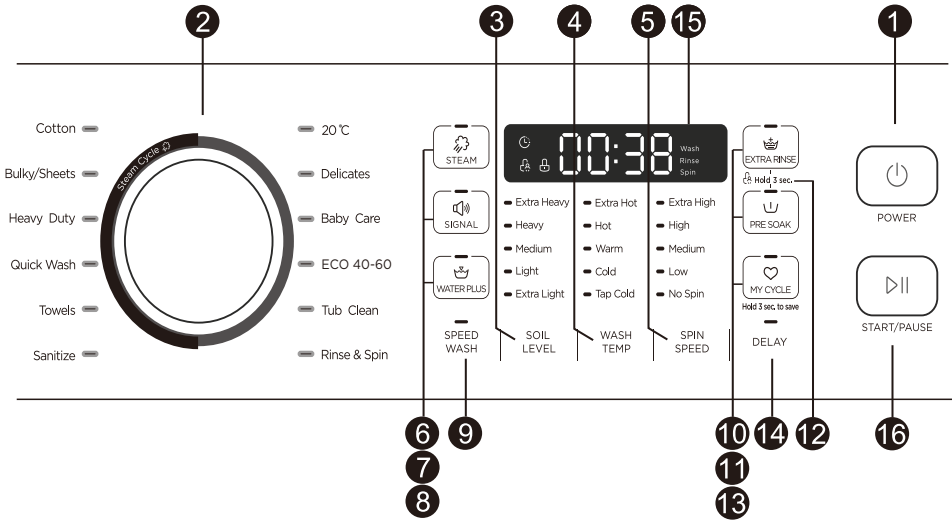

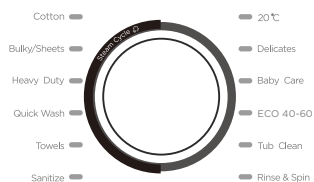

QUICK START

- 1 Press the Power button.  If the screen is dark, a press of the power button will 'wake up' the display.
- 2 Select a wash cycle . (Defaults are set for each cycle. These default settings can be changed. See Control setting for more information).



- 3 Press the START/PAUSE button. 

CONTROL SETTING

- 1 **Power**
Press  to “wake up” the display. If the display is active, press  to put the washer into standby mode.
NOTE: Pressing Power does not disconnect the appliance from the power supply.

2 Wash Cycles

The wash cycles are optimised for specific types of wash loads. The chart below will help you match the setting with the loads.

	Cotton	Hard-wearing textiles, heat-resistant textiles made of cotton or linen.
Washer Safety	Normal/ Colours	For heavily to lightly soiled colorfast cottons, household linens
	Bulky/ Sheets	For large items such as comforters, blankets, rugs and similar bulky items.
Operation Requirements	Heavy Duty	Washing the large and heavy clothing, such as overcoats or towels.
	Quick Wash	For lightly soiled items needed in a hurry Cycle time is approximately 40 minutes, depending on selected options.
Installation Instructions	Whites	For heavily to lightly soiled white laundrywork and play clothes.
	Towels	For items such as towels, sheets, pillowcases and dish cloths.
	Sanitise	For increased water temperature which will sanitise and kill more than 99.9% of many common bacteria found in home laundry. For best results, select the extra heavy soil setting when using the Sanitize cycle.
Washer Use	20°C	Washing brightly coloured clothes, this wash will help prevent colour fading.
	Delicates	For delicate, washable textiles, e.g. made of silk, satin, synthetic fibers or blended fabrics.
Washer Care	Baby Care	For washing babies clothes. This cycle has an increased rinse performance to protect babies skin.
	Sportswear	Washing the activewear.
Troubleshooting	ECO 40-60	Default 40°C, not selectable, suitable for laundry washing at about 40°C-60°C.
	Tub Clean	Use for cleaning the basket of residue and odour recommended use of at least once per month. NOTE: Never load laundry using Tub Clean. The laundry may become damaged See the Care and Cleaning section.
	Rinse & Spin	To quickly rinse and spin out any items at any time.

3 SOIL LEVEL

Change the **Soil** level to increase or decrease the wash time to remove different amounts of soil.

To change the **Soil** level, press the **Soil** level button until you have reached the desired setting. You can choose between Extra Light, Light, Medium, Heavy or Extra Heavy soil levels.

4 WASH TEMP

Adjust to select the proper main water temperature for the wash cycle. The Pre-Wash rinse water is always cold to help reduce energy usage and reduce setting of stains and wrinkles.

To change the wash temperature, press the wash Temp button until you have reached the desired setting.

You can choose between Tap Cold, Cold, Warm, Hot or Extra Hot.

Follow the fabric manufacturer's care label when selecting the wash temperature.

By design, to protect fabrics, not all wash temperatures are available for certain wash cycles.

5 SPIN SPEED

Changing the **Spin** speed changes the final **spin** speed of the cycles. Always follow the garment manufacturer's care label when changing the Spin speed.

To change the **Spin** speed, press the **Spin** speed button until you have reached the desired setting. You can choose between No Spin, Low, Medium, High or Extra High. Higher spin speeds are not available on certain cycles, such as Delicates. Higher spin speeds remove more water from the clothes and will help reduce dry time, but may also increase the possibility of setting wrinkles on some fabrics.

6 STEAM

Steam adds steam into the washer to assist with loosening stains on the Cotton, Bulky/Sheets, Heavy Duty, Quick Wash, Towels or Sanitise cycle.

To use:

1. Turn power ON and select a wash cycle.
2. Select the Add Steam button to activate steam.
3. Press the ►|| button.

7 SIGNAL

Use the Signal button to change the volume of the end-of-cycle signal.

Press the button until you reach the desired volume.

8 WATER PLUS

Increases the water level of the main wash.

To use:

1. Turn power ON and select a wash cycle.
2. Select the Add Water Plus button to activate water plus.
3. Press the ►|| button.

9 SPEED WASH

This option reduces the overall washer cycle time by optimising the wash, rinse and spin actions and/or gently raising the wash temperature to get clothes cleaned faster

To use:

1. Turn power on and select a wash cycle which has Time Saver as an option.
2. Make any adjustments to Soil, Temp and Spin as desired.
3. Press the Speed Wash button to reduce the overall wash time.
4. Press the ►|| button.

Option is available on Cotton, Bulky/Sheets, Heavy Duty, Towels, Sanitise or Baby Care cycles.

Total wash time will vary based on cycle chosen and options selected.

10 EXTRA RINSE

This option allows for an extra rinse during a cycle to remove excess dirt and detergent from soiled loads.

Rinse + Spin cycle, a drain and spin cycle can be achieved by pressing the **Extra Rinse** button until the light is no longer illuminated.

11 PRE - SOAK

For soaking your garments prior to the wash cycle. This option begins with a brief tumble and then proceeds to soak the clothes with water and detergent for a specified period of time. Once complete, the cycle will begin automatically. **Pre - Soak** must be selected prior to pressing **▶||** button.

The **Pre-Soak** time will add an additional 30 minutes to the overall wash time. High-efficiency detergent from the main wash compartment in the dispenser is used for the **Pre-Soak** period and main wash cycle.

12 EXTRA RINSE and PRE SOAK

 Hold 3 sec.

You can lock the controls to prevent any selections from being made. Or you can lock or unlock the controls after you have started a cycle.

Children cannot accidentally start the washer by touching buttons with this option selected.

To lock the washer, press and hold the **Extra Rinse and Pre Soak** buttons for 3 seconds.

To unlock the washer controls, press and hold **Extra Rinse and Pre Soak** buttons for 3 seconds.

NOTE: The **Power** button can still be used when the machine is locked.

13 MY CYCLE

Hold for 3 sec to save

To save a favourite cycle, set the desired setting for wash cycle, soil level, spin speed and wash temp settings and hold down the My Cycle button for 3 seconds, A beep will sound to indicate the cycle has been saved.

To use your custom cycle, press the **My Cycle** button before washing a load.

To change the saved cycle, set the desired setting and hold down the **My Cycle** button for 3 seconds.

NOTE: When using **My Cycle**, wash options cannot be modified after the cycle has been started.

NOTE: If you change wash options with **My Cycle** before starting the cycle, the **My Cycle** light will turn off and you will be returned to the base cycle.

14 DELAY

You can delay the start of a wash cycle for up to 24 hours. Press the Delay Wash button to choose the amount of time you want to delay the start of the wash cycle. Once the desired time is reached, press the ▶|| button. The machine will count down and start automatically at the correct time.

NOTE: If you do not fully close the door, a remainder signal will beep reminding you to do so.

NOTE: If you open the door when the delay is counting down, the machine will enter the pause state. You must close the door and press ▶|| button again in order to restart the countdown.

15 Display

Displays the approximate time remaining until the end of the cycle.

NOTE: The cycle time is affected by the water pressure in your home and the balance of the load in the washer. You may see the time remaining on the display increase to accommodate a slower spin speed to handle unbalanced loads.

Cycle status is also displayed and certain features such as Delay Wash or Steam are shown indicating they have been selected.

A Display

Wash Time	Delay Time
125	2H
End	Error
End	E 30

B Remain-Delay

C Child Lock

D Door Lock



16 ▶|| START/PAUSE

Press to start a wash cycle. If the washer is running, pressing it once will pause the washer. Press again to restart the wash cycle.

If you want add a garment, please press the ▶|| button. The washer will unlock the door. Press again to restart the cycle.

NOTE: In some cycles the washer will drain first, then unlock the door when it is paused.

NOTE: The washer performs automatic system checks after pressing the ▶|| button.

You may hear the door lock and unlock before water flows, this is normal.

FEATURES

THE DISPENSER DRAWER

Slowly open the dispenser drawer by pulling it out until it stops. After adding detergent slowly close the dispenser drawer. Closing the drawer too quickly could result in early dispensing of the bleach, fabric softener or detergent.

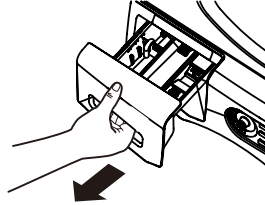

You may see water in the dispenser drawer at the end of the cycle. This is a result of the flushing/siphoning action and is part of the normal operation of the washer.

NOTE: Liquid detergent will drain into the washer drum as it is added.

- Detergent usage may need to be adjusted for water temperature, water hardness, size and soil level of the load. Avoid using too much detergent in your washer as it can lead to over sudsing and detergent residue being left on the clothes.

The Detergent Compartment

- High-efficient detergent is required for this washer. Use the detergent manufacturer's recommended amount.
- Add measured detergent to the front left detergent compartment of the dispenser drawer.

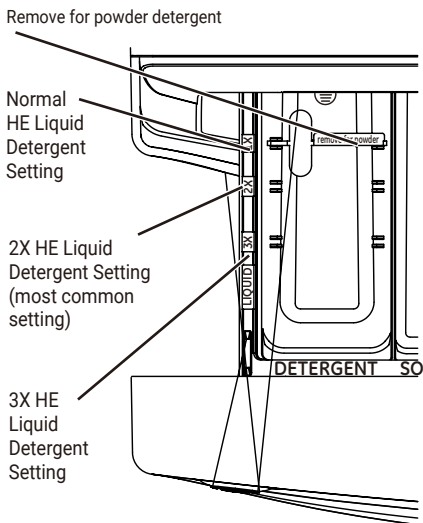

- Detergent is flushed from the dispenser at the beginning of the wash cycle. Either powdered or liquid detergent can be used.
- Powder Detergent - Remove the Detergent selection insert and place it in a safe location outside of the washer. Follow the detergent manufacturer's instructions when measuring the amount of powder to use.
- Detergent usage may need to be adjusted for water temperature, water hardness, size and soil level of the load. Avoid using too much detergent in your washer as it can lead to over sudsing and detergent residue being left on the clothes.
- Using more detergent than the recommended quantity can cause residue buildup on your washer.
- Liquid Detergent - Locate the concentration of your detergent on the bottle. Place the Detergent selection insert in the corresponding location depending on the concentration.

The Liquid Bleach Compartment

IMPORTANT: Be sure to identify the correct compartment for bleach before using.

If desired, measure out the recommended amount of liquid bleach, not to exceed 1/3cup (80 ml), and pour into the right compartment labeled "LIQUID BLEACH".

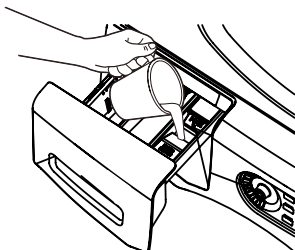

Do not exceed the maximum fill line. Overfilling can cause early dispensing of the bleach which could result in damaged clothes.

NOTE: Do not use powdered bleach in the dispenser.

The Fabric Softener Compartment

IMPORTANT: Be sure to identify the correct compartment for fabric softener before using.

If desired, pour the recommended amount of liquid fabric softener into the compartment labeled "FABRIC SOFTENER".

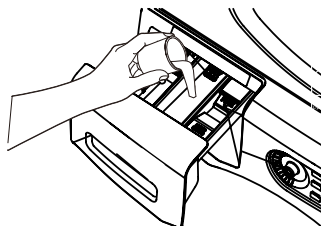

Use only liquid fabric softener in the dispenser

Dilute with water to the maximum fill line.

Do not exceed the maximum fill line. Overfilling can cause early dispensing of the fabric softener which could stain clothes.

NOTE: Do not pour fabric softener directly on the wash load.

LOADING AND USING THE WASHER

Always follow fabric manufacturer's care label when laundering.

SORTING WASH LOADS

Sort laundry into loads that can be washed together

COLOURS	SOIL	FABRIC	LINT
Whites	Heavy	Delicates	Lint Producers
Lights	Normal	Easy Care	Lint Collectors
Darks	Light	Sturdy Cottons	

- Combine large and small items in a load. Load large items first. Large items should not be more than half the total wash load.
- **Washing single items is not recommended.** This may cause an out-of-balance load. Add one or two similar items.
- Pillows and comforters should not be mixed with other items. This may cause an out-of-balance load.

WARNING



Fire Hazard

- Never place items in the washer that are dampened with gasoline or other flammable liquids.
- No washer can completely remove oil.
- Do not dry anything that has ever had any type of oil.
- Doing so can result in death, explosion, or fire.

PREPARING CLOTHES

To avoid snags during washing:

Follow these steps to maximize garment care.

- Close garment zippers, snaps, buttons and hooks.
- Mend seams, hems, tears.
- Empty all items from pockets.
- Remove non-washable garment accessories such as ornaments and non-washable trim materials.
- To avoid tangling, tie strings, draw ties and belt-like materials.
- Brush away surface dirt and lint.
- Promptly wash wet or stained garments to maximise results.
- Use nylon mesh garment bags to wash small items.
- Wash multiple garments at one time for best results.

LOADING THE WASHER

Wash drum may be fully loaded with loosely added items. Do not wash fabrics containing flammable materials (waxes, cleaning fluids, etc.).

To add items after the washer has started, press Pause/Add a Garment and wait until the door is unlatched. The washer may take up to 30 seconds to unlock the door after pressing Pause/Add a Garment depending on the machine conditions. Do not try to force open the door when it is locked. After the door unlocks, open gently. Add items, close the door and press Pause/Add a Garment to restart.

WASHER CARE

CLEANING

EXTERIOR

Immediately wipe off any spills. Wipe with damp cloth. Do not hit surface with sharp objects.

INTERIOR

To clean the interior of the washer, select the Tub Clean feature on the control panel. This Tub Clean cycle should be performed, at a minimum, once per month. This cycle will use more water in addition to bleach, to control the rate at which soils and detergents may accumulate in your washer.

NOTE: Read the instructions below completely before starting the Tub Clean cycle.

1. Remove any garments or objects from the washer and ensure the washer basket is empty.
2. Open the washer door and pour one cup or 250 ml of liquid bleach or other washing machine cleaner into the basket.

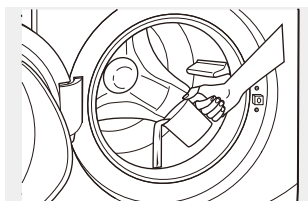

3. Close the door and select the Tub Clean cycle. Push the Pause/Add a Garment button.
4. When the Tub Clean cycle is working, the display will show the estimated cycle time remaining. The cycle will complete in about 90 minutes. Do not interrupt the cycle.

5. After the cycle is complete, leave the door open slightly for better ventilation.

If for any reason the cycle needs to be interrupted, the door will not open immediately. Forcing open the door at this stage may cause water to flood. The door will open after the water is drained to a level where it would not flood the floor.

Tub Clean may be interrupted by pressing the Pause/Add a Garment button in between cycles. A power cut might also interrupt the cycle. When the power supply is back, the Tub Clean cycle resumes where it had stopped. When interrupted, be sure to run a complete Tub Clean cycle before using the washer. If the Power pad is pressed during Tub Clean, the cycle will be lost.

IMPORTANT:

- Run Tub Clean with 1 Cup (250 ml) of bleach once a month.
- After the completion of a Tub Clean cycle, the interior of your washer may have a bleach smell.
- It is recommended to run a light colour load after the Tub Clean cycle.

DISPENSER DRAWER AREA

Detergent and fabric softener may build up in the dispenser drawer. Residue should be removed once or twice a month.

Lock tab is visible only after drawer has been pulled open.

Remove the drawer by first pulling it out until it stops. Then reach back into right rear corner of the drawer cavity and press down firmly on the lock tab, pulling out the drawer.

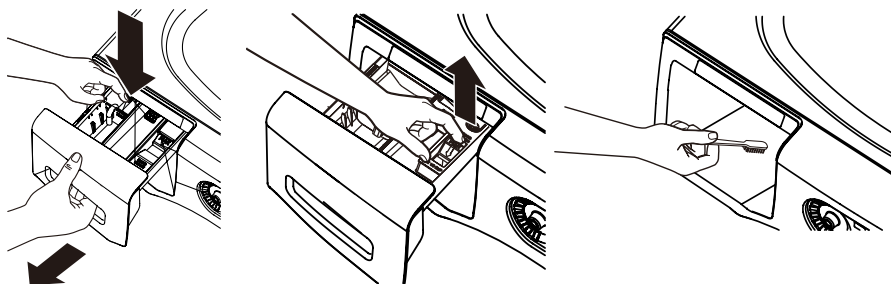

CLEANING THE DRAIN PUMP FILTER

Due to the nature of the front-load washer, it is sometimes possible for small articles to pass to the pump. The washer has a filter to capture lost items so they are not dumped to the drain. To retrieve lost items, clean out the pump filter.

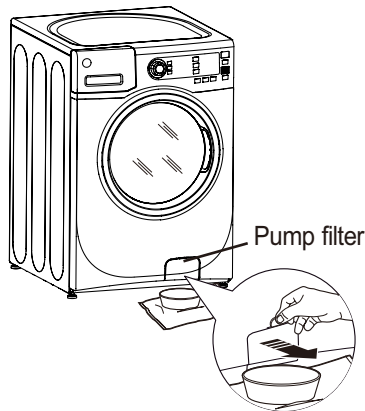

1. Using a coin or flat screw driver in the notch on the door, open the access door.

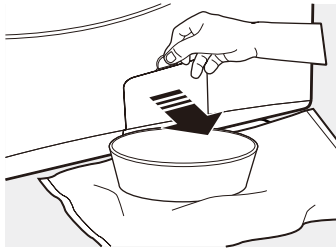

2. Place a shallow pan or dish under the pump access door and towels on the floor in front of the washer to protect the floor. It is normal to catch a cup of water when the filter is removed.
3. Pull down the pour spout.



4. Turn the pump filter counterclockwise and remove the filter. Open slowly to allow the water to drain.

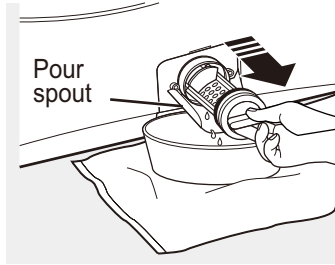

5. Clean the debris from the filter.
6. Replace the filter and turn clockwise. Tighten securely.
7. Flip up the pour spout.
8. Close the access door

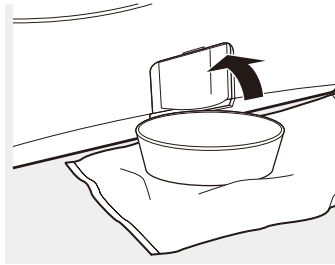

CLEANING THE DOOR GASKET

1. Open the washer door. Using both hands, press down the door gasket. Remove any foreign objects if found trapped inside the gasket. Make sure there is nothing blocking the holes behind the gasket.



2. While holding down the door gasket, inspect the interior gasket by pulling it down with your fingers. Remove any foreign objects if found trapped inside this gasket. Make sure there is nothing blocking the holes behind the gasket.

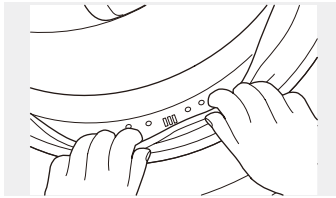

3. When you are finished cleaning the door gasket, remove your hands and the gasket will return to the operating position.

MOVING, STORAGE AND LONG VACATIONS

Ask the service technician to remove water from drain pump and hoses. Do not store the washer where it will be exposed to the weather. When moving the washer, the tub should be kept stationary by using the shipping bolts removed during installation. See Installation Instructions in this book.

Be sure the water supply is shut off at the faucets. Drain all water from the hoses if the weather will be below freezing.

BEFORE YOU CALL FOR SERVICE...

Troubleshooting Tips

Save time and money! Review the charts on the following pages first and you may not need to call for service.

Washer Safety
Operation Requirements
Installation Instructions
Washer Use
Washer Care
Troubleshooting

Problem	Possible Cause	What To Do
Not draining Not spinning Not agitating	Load is out of balance	<ul style="list-style-type: none"> • Redistribute the clothes and run drain & spin or rinse & spin. • Increase load size if washing small load containing heavy and light items.
	Pump clogged	<ul style="list-style-type: none"> • See page 27 on how to clean the Pump Filter.
	Drain hose is kinked or improperly connected	<ul style="list-style-type: none"> • Straighten drain hose and make sure washer is not sitting on it.
	Household drain may be clogged	<ul style="list-style-type: none"> • Check household plumbing. You may need to call a plumber.
	Drain hose siphoning; drain hose pushed too far down the drain	<ul style="list-style-type: none"> • Ensure there is an air gap between hose and drain.
Leaking water	Door gasket is damaged	<ul style="list-style-type: none"> • Check to see if gasket is seated and not torn. Objects left in pockets may cause damage to the washer (nails, screws, pens, pencils).
	Door gasket not damaged	<ul style="list-style-type: none"> • Water may drip from the door when the door is opened. This is a normal operation. • Carefully wipe off rubber door seal. Sometimes dirt or clothing is left in this seal and can cause a small leak.
	Check back left of washer for water	<ul style="list-style-type: none"> • If this area is wet, you have oversudsing condition. Use less detergent.

Problem	Possible Cause	What To Do
Leaking water (cont.)	Fill hoses or drain hose is improperly connected	<ul style="list-style-type: none"> • Make sure hose connections are tight at washer and faucets and make sure end of drain hose is correctly inserted in and secured to drain facility.
	Household drain may be clogged	<ul style="list-style-type: none"> • Check household plumbing. You may need to call a plumber.
	Dispenser clogged	<ul style="list-style-type: none"> • Powder soap may cause clogs inside the dispenser and cause water to leak out the front of the dispenser. Remove drawer and clean both drawer and inside of dispenser box. Please refer to Cleaning the Washer section.
	Incorrect use of detergent	<ul style="list-style-type: none"> • Use HE and correct amount of detergent.
	Dispenser box crack	<ul style="list-style-type: none"> • If new installation, check for crack on inside of dispenser box.
Clothes too wet	Load is out of balance	<ul style="list-style-type: none"> • Redistributes clothes and run drain & spin or rinse & spin. • Increase load size if washing small load containing heavy and light items. • The machine will slow the spin speed down to 400 rpm if it has a hard time balancing the load. This speed is normal.
	Pump clogged	<ul style="list-style-type: none"> • See page 27 on how to clean the Pump Filter.
	Overloading	<ul style="list-style-type: none"> • The dry weight of the load should be less than 18 Kg.
	Drain hose is kinked or improperly connected	<ul style="list-style-type: none"> • Straighten drain hose and make sure washer is not sitting on it.

Problem	Possible Cause	What To Do
Clothes too wet (cont.)	Household drain may be clogged	<ul style="list-style-type: none"> • Check household plumbing. You may need to call a plumber.
	Drain hose siphoning; drain hose pushed too far down the drain	<ul style="list-style-type: none"> • Ensure there is an air gap between hose and drain.
Incomplete cycle or timer not advancing	Automatic load redistribution	<ul style="list-style-type: none"> • Timer adds 3 minutes to cycle for each re-balance. 11 or 15 re-balances may be done. This is normal operation. Do nothing; the machine will finish the wash cycle.
	Pump clogged	<ul style="list-style-type: none"> • See page 27 on how to clean the Pump Filter
	Drain hose is kinked or improperly connected	<ul style="list-style-type: none"> • Straight drain hose and make sure washer is not sitting on it.
	Household drain may be clogged	<ul style="list-style-type: none"> • Check household plumbing. You may need to call a plumber.
	Drain hose siphoning; drain hose pushed too far down the drain	<ul style="list-style-type: none"> • Ensure there is an air gap between hose and drain.
Loud or unusual noise; vibration or shaking	Cabinet moving	<ul style="list-style-type: none"> • Washer is designed to move 1/4 " to reduce forces transmitted to the floor. This movement is normal.
	All rubber leveling legs are not firmly touching the floor	<ul style="list-style-type: none"> • Push and pull on the back right and then back left of your washer to check if it is level. If the washer is uneven, adjust the rubber leveling legs so they are all firmly touching the floor and locked in place. Your installed should correct this problem.
	Unbalanced load	<ul style="list-style-type: none"> • Open door and manually redistribute load. To check machine, run rinse and spin with no load. If normal, unbalance was caused by load.
	Pump clogged	<ul style="list-style-type: none"> • See page 27 on how to clean the Pump Filter.

Washer Safety
 Operation Requirements
 Installation Instructions
 Washer Use
 Washer Care
 Troubleshooting

Problem	Possible Cause	What To Do
No power/ washer not working or dead	<p>Washer is unplugged</p> <p>Circuit breaker/fuse is tripped/blown</p> <p>Automatic self system checks</p>	<ul style="list-style-type: none"> • Make sure cord is plugged securely into a working outlet. • Turn cold faucet fully on. • Check house circuit breaker/fuses. Replace fuses or reset breaker Washer should have separate outlet. • First time the washer is plugged in, automatic checks occur. It may take up to 20 seconds before you can use your washer. This is normal operation.
Snags, holes, tears, rips or excessive wear	<p>Overloaded</p> <p>Pens, pencils, nails, screws or other objects left in pockets</p> <p>Pins, snaps, hooks, sharp buttons, belt buckles, zippers and sharp objects left in pockets</p>	<ul style="list-style-type: none"> • The dry weight of the load should be less than 18 Kg. • Remove loose items from pockets. • Fasten snaps, hooks, buttons and zippers.
Control time wrong or changes	This is normal	<ul style="list-style-type: none"> • During spin the washer may need to re-balance the load sometimes to reduce vibrations. When this happens, the estimated time is increased causing time left to increase or jump.
Not enough water	This is normal	<ul style="list-style-type: none"> • Horizontal washers do not require the tub to fill with water like top-load washers.
Washer pauses or has to be restarted, or washer door is locked and will not open	Pump clogged	<ul style="list-style-type: none"> • See page 27 on how to clean the Pump Filter

Problem	Possible Cause	What To Do
Door unlocks or press Pause/Add a Garment and machine doesn't operate	This is normal	<ul style="list-style-type: none"> • Front-load washers start up differently than top-load washers, and it takes 30 seconds to check the system. The door will lock and unlock.
	Incorrect operation	<ul style="list-style-type: none"> • Simply open and close the door firmly; then press ▶II
Water does not enter washer or enters slowly	Automatic self system checks	<ul style="list-style-type: none"> • After ▶II is pressed, the washer does several system checks. Water will flow 60 seconds after ▶II is pressed.
	Water supply is turned off Water valve screens are stopped up	<ul style="list-style-type: none"> • Turn on water supply. • Turn off the water source and remove the water connection hoses from the upper back of the washer. Use a brush or toothpick to clean the screens in the machine. Reconnect the hose and turn the water back on.
Wrinkling	Improper sorting	<ul style="list-style-type: none"> • Avoid mixing heavy items (like work clothes) with light items (like blouses).
	Overloading	<ul style="list-style-type: none"> • Load your washer so clothes have enough room to move freely.
	Incorrect wash cycle	<ul style="list-style-type: none"> • Match cycle selection to the type of fabric you are washing (especially for easy care loads).
	Repeated washing in water that is too hot	<ul style="list-style-type: none"> • Wash in warm or cold water

Problem	Possible Cause	What To Do
Grayed or yellowed clothes	Not enough detergent	<ul style="list-style-type: none"> • Use correct amount of detergent.
	Not using HE (high-efficiency) detergent	<ul style="list-style-type: none"> • Use HE detergent.
	Hard water	<ul style="list-style-type: none"> • Use hottest water safe for fabric. • Use a water conditioner like install a water softener.
	Detergent is not dissolving	<ul style="list-style-type: none"> • Try a liquid detergent.
Coloured spots	Dye transfer	<ul style="list-style-type: none"> • Sort clothes by colour. If fabric label states wash separately unstable dyes may be indicated.
	Incorrect use of fabric softener	<ul style="list-style-type: none"> • Check fabric softener package for instructions and follow directions for using dispenser.
Slight variation in metallic colour	Dye transfer	<ul style="list-style-type: none"> • Sort whites or lightly coloured items from dark colours. • Promptly remove wash load from washer.
	This is normal appearance	<ul style="list-style-type: none"> • Due to the metallic properties of paint used for this unique product, slight variations of colour may occur due to viewing angles and lighting conditions.

Problem	Possible Cause	What To Do
Smell inside your washer	Washer unused for a long time, not using recommended quality of HE detergent or used too much detergent	<ul style="list-style-type: none"> • Run a Tub Clean cycle once a month. • In the case of strong smell, you may need to run the Tub Clean cycle more than once a month. • Use only the amount of detergent recommended on the detergent container • Use only HE (high-efficiency) detergent. • Always remove wet items from the washer promptly after machine stops running. • Leave the door slightly open for the water to air dry. Close supervision is necessary if this appliance is used by or near children. Do not allow children to play on, with or inside this or any other appliance.
Detergent leak	Incorrect placement of detergent insert	Make sure detergent insert is properly located and fully seated. Never put detergent above max line.
Improper dispensing of softener or bleach	<p>Dispenser clogged</p> <p>Softener or bleach is filled above the max line</p> <p>Softener or bleach cap issue</p>	<p>Clean the dispenser monthly drawer to remove buildup of chemicals.</p> <p>Make sure to have the correct amount of softener or bleach.</p> <p>Make sure softener and bleach cap for dispenser are seated or they will not work.</p>

Washer Safety
 Operation Requirements
 Installation Instructions
 Washer Use
 Washer Care
 Troubleshooting

ERROR CODES

Description	Reason	Solution
E30	Door is not closed properly	Restart after the door is closed. Check if the clothes is stuck.
E10	Water injecting problem while washing	Check if the water pressure is too low. Straighten the water hoses. Check if the inlet valve filter is blocked.
E21	Overtime water draining	Check if the drain hose is blocked, clean drain filter
E12	Water overflow	Restart the washer.
EXX	Others	Please try again first, call up service line if there are still troubles.

MAINTENANCES

Product fiche concerning to Regulation (EU) No 1061/2010

Trade mark	Cater-Wash
Model identifier	CW8518
Rated capacity in kg of cotton laundry	18
Energy efficiency class on a scale from A+++ (most efficient) bis D (least efficient)	A+++
Energy consumption 197 kWh per year, based on 220 standard washing cycles for Intensive programmes at 60 °C and 40 °C at full and partial load, and the consumption of the low-power modes. Actual energy consumption will depend on how the appliance is used.	
Energy consumption of the Intensive 60°C programme at full load	2.12kwh
Energy consumption of the Intensive 60°C programme at partial load	1.80kwh
Energy consumption of the Intensive 40°C programme at partial load	1.51kwh
Weighted power consumption of the off-mode	0.50W
Weighted power consumption of the left-on mode	1.00W
Water consumption 15840litres per year, based on 220 standard washing cycles for Intensive programmes at 60 °C and 40 °C at full and partial load. Actual water consumption will depend on how the appliance is used.	
spin-drying efficiency class B on a scale from G (least efficient) to A (most efficient)	
maximum spin speed	800
Remaining moisture content	62%
'Intensive 60°C programme' and the 'Intensive 40°C programme' are the standard washing programmes to which the information in the label and the fiche relates, that these programmes are suitable to clean normally soiled cotton laundry and that they are the most efficient programmes in terms of combined energy and water consumption.	
Programme time of Intensive 60°C programme at full load	210min
Programme time of Intensive 60°C programme at half load	195min
Programme time of Intensive 40°C programme at half load	195min
duration time of left-on mode	1 min
Airborne acoustical noise emissions during washing phase	63dB
Airborne acoustical noise emissions during spinning phase	79dB
'built-in' washing machine	no

Energy test program: Heavy Duty, Temp: Warm/Hot; Speed: the highest speed; Other as the default.

MAINTENANCES

Supplier's name: **Caterkwik**

Supplier's Address The Lakeland Catering Centre, Newlands, Ulverston, Cumbria LA12 7QQ

Model identifier: **CW8518**

General product parameters:

Parameter	Value		Parameter	Value	
Rated capacity ^(a) (kg)	18.0		Dimensions in cm	Height	1010
				Width	686
				Depth	868
EEI _w ^(a)	79.8		Energy efficiency class ^(a)	D	
Washing efficiency index ^(a)	1.04		Rinsing effectiveness (g/kg) ^(a)	5.0	
Energy consumption in kWh per cycle, based on the eco 40-60 programme. Actual energy consumption will depend on how the appliance is used.	0.882		Water consumption in litre per cycle, based on the eco 40-60 programme. Actual water consumption will depend on how the appliance is used and on the hardness of the water.	69	
Maximum temperature inside the treated textile ^(a) (°C)	Rated capacity	50	Remaining moisture content ^(a) (%)	Rated capacity	62
	Half	34		Half	62
	Quarter	30		Quarter	62
Spin speed ^(a) (rpm)	Rated capacity	800	Spin-drying efficiency class ^(a)	C	
	Half	800			
	Quarter	800			
Programme duration ^(a) (h:min)	Rated capacity	4 : 00	Type	free-standing	
	Half	3 : 00			
	Quarter	3 : 00			
Airborne acoustical noise emissions in the spinning phase ^(a) (dB(A) re 1 pW)	80		Airborne acoustical noise emission class ^(a) (spinning phase)	C	
Off-mode (W)	0.50		Standby mode (W)	N/A	
Delay start (W) (if applicable)	4.00		Networked standby (W) (if applicable)	N/A	

This product has been designed to release silver ions during the washing cycle

NO

Additional information:

^(a) for the eco 40-60 programme.

^(b) changes to these items shall not be considered relevant for the purposes of paragraph 4 of Article 4 of Regulation (EU) 2017/1369.

^(c) if the product database automatically generates the definitive content of this cell the supplier shall not enter these data.

CATER-WASH

18kg Washing Machine - CW8518



Caterkwik Ltd

e: info@caterwash.com

t: 01229 480001

w: www.caterwash.com