

robot coupe®



CL 50 Gourmet

SUMMARY

■ WARRANTY

■ IMPORTANT WARNING

■ INTRODUCTION TO YOUR NEW
VEGETABLE PREPARATION MACHINE
CL 50 Gourmet

■ SWITCHING ON THE MACHINE

- Advice on electrical

■ ASSEMBLY

■ USES AND CHOICE OF DISCS

■ CLEANING

■ MAINTENANCE

- Blades, plates and graters

■ SAFETY

■ TECHNICAL DATA

- Exploded views
- Electric and wiring diagrams

ROBOT COUPE U.S.A., INC. LIMITED WARRANTY

YOUR NEW ROBOT COUPE PRODUCT IS WARRANTED TO THE ORIGINAL PURCHASER FOR A PERIOD OF ONE YEAR FROM THE DATE OF PURCHASE.

This LIMITED WARRANTY is against defects in the material and/or workmanship, and includes labor for replacement of defective parts, provided repairs are performed by an authorized service agency (see attached list).

The Customer must inform the Service Agency of the possibility of warranty coverage and provide a copy of the dated sales or delivery receipt

BEFORE WARRANTY REPAIRS ARE BEGUN. Replacement parts and accessories are warranted for ninety (90) days from the date of purchase when purchased separately and will be verified by dated sales receipt OR packing slip which lists that item.

All parts or accessories replaced under warranty must be returned to the Service Agency.

THE FOLLOWING ARE NOT COVERED BY THE ROBOT COUPE U.S.A. INC LIMITED WARRANTY:

- 1** - Damage caused by abuse, misuse, dropping, or other similar damage caused by or resulting from failure to follow assembly, operating, cleaning, user maintenance or storage instructions.
- 2** - Labor to sharpen and/or replacements for blades that have become blunt, chipped or worn after a normal or excessive period of use.
- 3** - Materials or labor to replace or repair scratched, stained, chipped, pitted, dented or discolored surfaces, blades, knives, attachments or accessories.
- 4** - Any alteration, addition, or repair that has not been carried out by the company or an approved service agency.
- 5** - Transportation of the appliance to or from an approved service agency.
- 6** - Labor charges to install or test new attachments or accessories (i.e., bowls, plates, blades, attachments), which have been replaced for any reason.

7 - The cost of changing direction-of-rotation of three-phase electric motors (Installer is responsible).

8 - SHIPPING DAMAGES. Visible and/or hidden damage is the responsibility of the freight carrier. The consignee must inform the carrier and consignor immediately, or upon discovery in the case of hidden defects.

KEEP ALL ORIGINAL CONTAINERS AND PACKING MATERIALS FOR CARRIER INSPECTION.

Neither ROBOT COUPE U.S.A., INC. nor its affiliated companies or any of its distributors, directors, agents, employees, or insurers will be liable for indirect damage, losses, or expenses linked to the appliance or the inability to use it.

The ROBOT COUPE U.S.A., INC. warranty is given expressly and in lieu of all other warranties, expressed or implied, for merchantability and for fitness toward a particular purpose and constitutes the only warranty made by ROBOT COUPE U.S.A., INC..

IMPORTANT WARNING



WARNING : In order to limit accidents such as electric shocks or personal injury, and in order to limit material damage due to misuse of the appliance, please read these instructions carefully and follow them strictly. Reading the operating instructions will help you get to know your appliance and enable you to use the equipment correctly. Please read these instructions in their entirety and make sure that anyone else who may use the appliance also reads them beforehand.

UNPACKING

- Carefully remove the equipment from the packaging and take out all the boxes or packets containing attachments or specific items.
- **WARNING** - some of the tools are very sharp e.g. blades, discs... etc.

INSTALLATION

- We recommend you install your machine on a perfectly stable solid base.

CONNECTION

- Always check that your mains supply corresponds to that indicated on the identification plate on the motor unit and that it can withstand the amperage.
- The machine must be earthed.

HANDLING

- Always take care when handling the blades, as they are extremely sharp.

ASSEMBLY PROCEDURES

- Follow the various assembly procedures carefully (see page 6) and make sure that all the attachments are correctly positioned.

USE

- Never try to override the locking and safety systems.
- Never insert an object into the container where the food is being processed.
- Never push the ingredients down with your hand.
- Do not overload the appliance.
- Never switch the appliance on when it is empty.

CLEANING

- As a precaution, always unplug your appliance before cleaning it.
- Always clean the appliance and its attachments at the end of each cycle.
- Never immerse the motor unit in water.
- For parts made from aluminum, use cleaning fluids intended for aluminum.

- Do not put the lid in dishwasher.
- For plastic parts , do not use detergents that are too alkaline (e.g., containing too much caustic soda or ammonia).
- Robot-Coupe can in no way be held responsible for the user's failure to follow the basic rules of cleaning and hygiene.

MAINTENANCE

- Before opening the motor housing, it is absolutely vital to unplug the appliance.
- Check the seals and washers regularly and ensure that the safety devices are in good working order.
- It is particularly important to maintain and check the attachments since certain ingredients contain corrosive agents, e.g. citric acid.
- Never operate the appliance if the power cord or plug has been damaged or if the appliance fails to work properly or has been damaged in any way.
- Do not hesitate to contact your local Maintenance Service if something appears to be wrong.

INTRODUCTION TO YOUR NEW CL 50 Gourmet VEGETABLE PREPARATION MACHINE

The CL 50 Gourmet is perfectly geared to professional needs. It can perform any number of tasks, which you will gradually discover as you use it.

This model is equipped with a metal bowl and a stainless steel motor base.

Thanks to its simple design, all components requiring frequent handling for maintenance or cleaning can be fitted and removed in a trice.

This manual contains important information designed to help the user get the most out of this vegetable preparation machine.

We therefore recommend that you read it carefully before using your machine. We have also included a few examples to help you get the feel of your new machine and appreciate its numerous advantages.

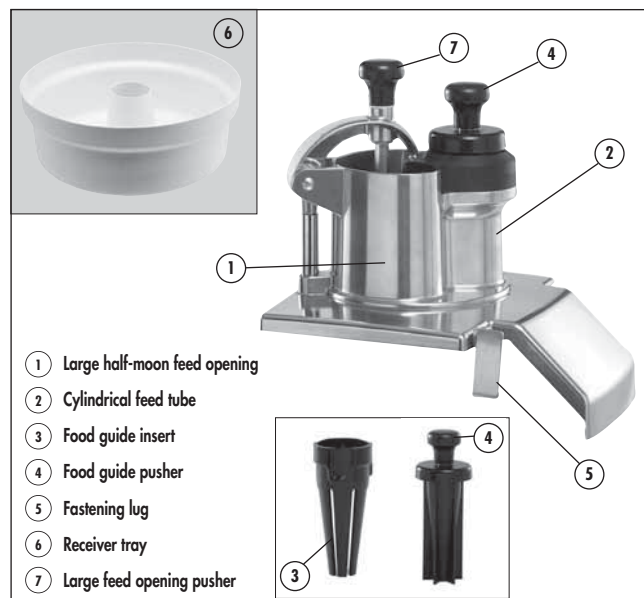

SWITCHING ON THE MACHINE

All users should read the manual before operating the machine.

Before connecting, check that your power supply corresponds to that indicated on the machine's identification plate.

ASSEMBLY

1) With the motor base facing you, place the discharge plate on the bottom of the bowl.

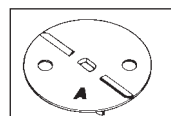
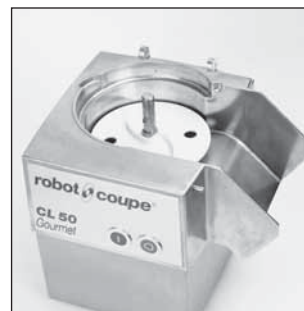

SIDE A facing upwards (ejection rib downwards) for any vegetables or citrus fruit which require careful handling (tomatoes, mushrooms...).

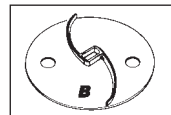

SIDE B facing upwards (ejection rib upwards) for all other types of fruit or vegetables.

2) Position your chosen disc:



a) **If you have opted for a slicing, grating or julienne disc:**

Position the disc on the motor shaft. To ensure that it is correctly positioned, turn it in a clockwise direction.

! WARNING

Never use a disc with a slicing thickness of more than 10 mm.

b) **You have chosen a dicing unit:**

i.e. a grid and a special slicing disc for diced vegetables.

Slicing discs and dicing grids can be mounted in the following combinations:

Slicer \ Dicing grid	5 x 5 mm	8 x 8 mm	10 x 10 mm	14 x 14 mm
5 mm	•			
8 mm		•		
10 mm			•	•

Place the dicing grid in the bowl of the vegetable processor.

Make sure that the spur on the grid is fully engaged in the locking slot of the motor base.



Next, fit the corresponding slicing disc (straight-edged blade) and rotate in a clockwise direction to ensure that it is correctly positioned.

c) If you want to use the French fries potatoes cutting equipment:

This equipment comprises a French fries grid and a special French fries slicing disc.

Position the French fries grid in the vegetable preparation bowl. Check that it is correctly positioned with the French fries plate positioned at the outlet.

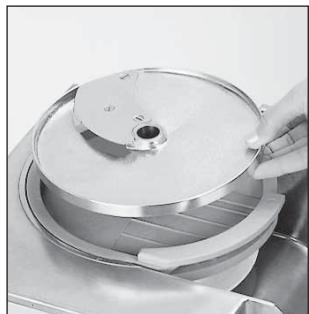
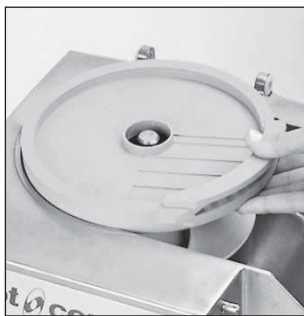

Next fit the appropriate slicing disc and rotate in a clockwise direction to check that it is correctly positioned.



d) If you have selected a dicing or ripple-cut disc :

Position the disc on the motor shaft.

! WARNING

The ripple-cut and fine-dicing discs are both fitted with a driving pinion. If the motor shaft and driving pinion come into contact, you will be unable to close the lid. In which case, simply turn the disc manually 90°.

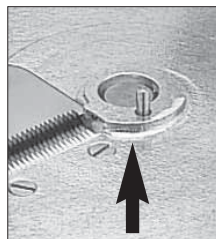

e) You only need to process small amounts :

When processing small amounts, we recommend you use the receiver tray.

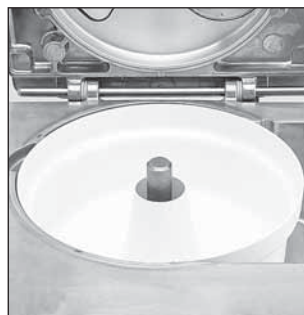

With the motor unit facing you, place the tray at the bottom of the bowl.

Position the disc of your choice on the motor shaft. Maximum capacity: 600 g diced potatoes (3 x 3 x 3 mm).

If you have trouble removing the disc, simply push the tray up with your hand to free the disc from the motor shaft.

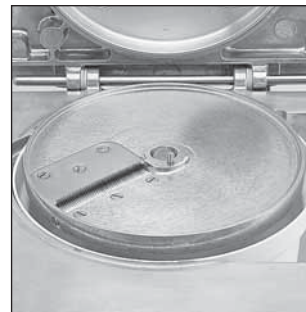

! WARNING

The receiver tray cannot be used with the dicing or French Fries equipments.

3) Position the head of the vegetable preparation machine on the motor shaft. The fastening hook should now be facing you, on your right.

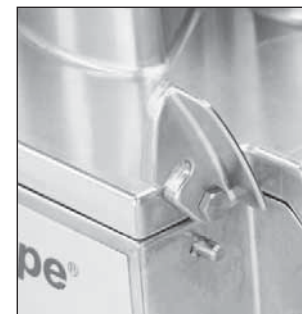
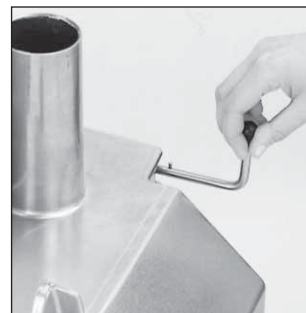
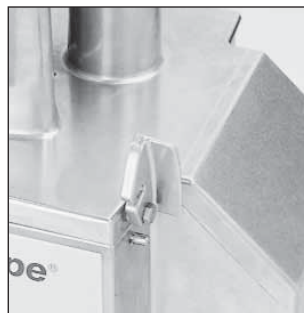

4) Position the head of the vegetable preparation machine on the motor shaft. The fastening hook should now be facing you, on your right.

TO CHANGE THE DISC:

1) With the motor base facing you, use your right hand to undo the aluminium fastening hook which holds the vegetable preparation head on the motor base.

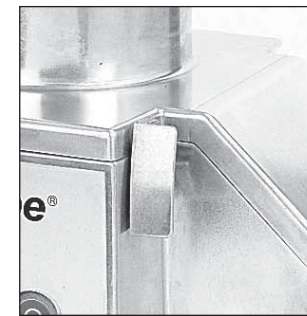

Lift the vegetable preparation head, tilting it back to release the bowl.

2) Remove the disc by lifting it from underneath using the hub and if necessary, turn in an anti-clockwise direction to release...

If you have been using a dicing unit, we recommend you remove the grid and the disc at the same time. This will be easier if you first rotate the emptying disc.

3) When fitting dicing equipment, we recommend that you clean the inside of the bowl with a damp cloth or sponge, particularly the part onto which the grid is to be fitted.

Always use a properly cleaned grid.

Never process soft foodstuffs after hard ones without properly cleaning the grid beforehand.

4) Fit the discharge plate, disc or dicing equipment as indicated in "assembly procedures" in points 1) and 2).

5) Close the lid of the vegetable preparation machine and lock onto the motor base using the fastening hook.

USES AND CHOICE OF DISCS

The lid of the vegetable processor features two feed openings:

- a **wide feed** opening for processing vegetables such as cabbage and celery.
- a **narrow feed** opening for long vegetables, guaranteeing a remarkable degree of cutting precision. Cutting quality can be optimized if the compartment is used as a cutting guide.







USING THE WIDE FEED OPENING

- Raise the pusher to gain access to the feed opening.
- Fill the feeder right up to the top with vegetables.
- Lower the pusher so that it is flush with the top of the feed opening.
- Exert a downwards pressure on the pusher. This pressure should just accompany the cutting process and will vary according to the type of cut. Remember that too great a pressure will place unnecessary strain on the appliance.
- Cut cabbages in half and remove the core before processing, in order to avoid unnecessary strain and ensure an end-product of a higher quality.

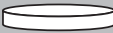
USING THE WIDE FEED OPENING

Fill the feeder right up to the top with vegetables. Apply a downwards pressure on the pusher and maintain it until all the vegetables have been processed.

Always press the vegetables down with a pusher to improve cutting efficiency.

SLICERS		
S 0,8	cabbage	
S 1	carrot / cabbage / cucumber / onion / potato / leek	
S 2 / S 3	lemon / carrot / mushroom / cabbage / potato / cucumber / zucchini / onion / leek / bell pepper	
S 4 / S 5	eggplant / beet root / carrot / mushroom / cucumber / bell pepper / radish / lettuce / potato / leek / tomato	
S 8 / S 10	eggplant / potato / zucchini / carrot	
RIPPLE CUT SLICERS		
R 2	beet root / potato / carrot / zucchini	
R 3	beet root / potato / carrot / zucchini	
R 5	beet root / potato / carrot / zucchini	
GRATERS		
G 1,5	céleriak / cheese	G 7 cabbage / cheese
G 2	carrot / céleriak / cheese	G 9 cabbage / cheese
G 3	carrot	Parmesan / chocolate
G 5	cabbage / cheese	Radish
JULIENNE		
J 2x2	carrot / céleriak / potato	
J 2x4	carrot / beet root / zucchini / potato	
J 2x6	carrot / beet root / zucchini / potato	
J 4x4	eggplant / beet root / zucchini / potato	
J 6x6	eggplant / beet root / céleriak / zucchini / potato	
J 8x8	céleriak / potato	
DICE		
D 5x5x5	carrot / zucchini / cucumber / céleriak	
D 8x8x8	potato / carrot / zucchini / beet root	
D 10x10x10	potato / carrot / zucchini / beet root / turnip / onion / apple (fruit)	
D 14x14x10	potato / carrot / zucchini / beet root / céleriak	
FINE-DICING		
FD 2x2x2	carrot / cucumber / radish / zucchini / céleriak / beet root / potato / turnip	
FD 3x3x3	carrot / cucumber / radish / zucchini / bell pepper / céleriak / beet root / potato / turnip	
FD 4x4x4	zucchini / bell pepper / céleriak / beet root / potato / turnip	
RIPPLE-CUT		
RC 4 mm	zucchini / carrot / potato / emmenthal cheese / beet root / cucumber / turnip	
RC 6 mm	zucchini / carrot / potato / emmenthal cheese / beet root / cucumber / turnip	

FRENCH FRIES		
F 8x8	potato	
F 10x10	potato	
F 10x16	potato	

CLEANING

! WARNING

Always unplug your food processor before cleaning (risk of electric shock).

Dishwashers are best avoided in order to prevent the aluminum from becoming tarnished. Instead we recommend that you clean the machine by hand, using a "soft metal safe" detergent.

The continuous feed lead, discharge plates, and cutting plates can be cleaned in a dishwasher. However, we suggest that you use a mild (non-corrosive) detergent designed for soft metals such as aluminum.

NEVER IMMERSE THE MOTOR BASE IN WATER. CLEAN IT WITH A DAMP (NOT DRIPPING), CLOTH OR SPONGE.

• SMALL DICING DISCS / DICING GRID :

The cutting edges of the small dicing discs and dicing grids have been precision-sharpened.

To maintain a consistently high cutting quality, make sure the edges are not damaged during cleaning.

To clean the dicing plates, we advise you to use a brush.

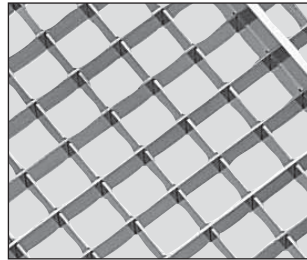
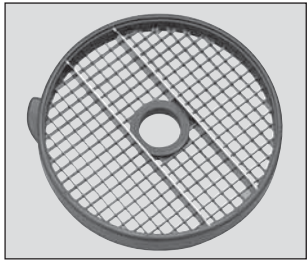
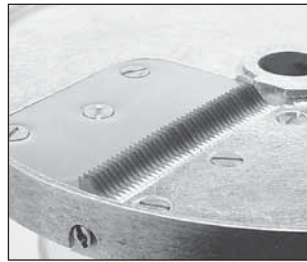

! IMPORTANT
 Check that your detergent is suitable for cleaning plastic parts. Some washing agents are too alkaline (e.g. high levels of caustic soda or ammonia) and totally incompatible with certain types of plastic, causing them to deteriorate rapidly. Never put them in the dishwasher.

MAINTENANCE

• BLADES, PLATES AND GRIDS

The blades on the slicing and julienne plates and the grids on the grating plates are all subject to wear and should be changed as required to ensure high quality cutting.

SAFETY

! WARNING
 The cutting plates are very sharp. Wear cut resistant gloves when handling the plates.

1) The CL 50 Gourmet is fitted with a safety system that turns the machine off when the lead is opened or if the lid latch is opened. **If this system should ever fail, the machine should be removed from use and serviced immediately.**

To restart your machine, simply close the feed lead, close the lid latch and press the green switch.

2) The CL 50 Gourmet is fitted with a temperature fuse that automatically stops the motor if the machine is left on for too long or overloaded. If this happens, allow the machine to cool completely before restarting. If the machine has become jammed press the off button and UNPLUG the machine from the wall outlet, and restart by first pressing the reset button located on the bottom of the motor base. Then close the lead / attachment, close the latch, and press the on button.

! WARNING

- Do not open the feed lead until the motor has come to a complete stop.
- Never tamper with or defeat the purpose of the locking and safety systems.
- Never place anything other than food products into the entry port.
- Never put anything into the exit port.
- Always use the food pushers to force the food through the entry ports.
- Do not overload the machine or apply excess pressure with the food pushers.

SERVICE

See warranty first then;

Should your unit require service, check with your distributor to see where local service is available. If not or if you wish your unit to be serviced at the factory, call for return instructions and ship the unit prepaid to our factory address.

PH : 1-800-824-1646

Robot-Coupe USA, Inc

Service Department Repair

264 South Perkins Street

Ridgeland, MS 39157

For service in Canada contact the Robot-Coupe USA factory for repair instructions.

robot coupe® U.S.A., Inc.

CL 50 Gourmet A

Serial number / N° de serie
- 456 - - - - -

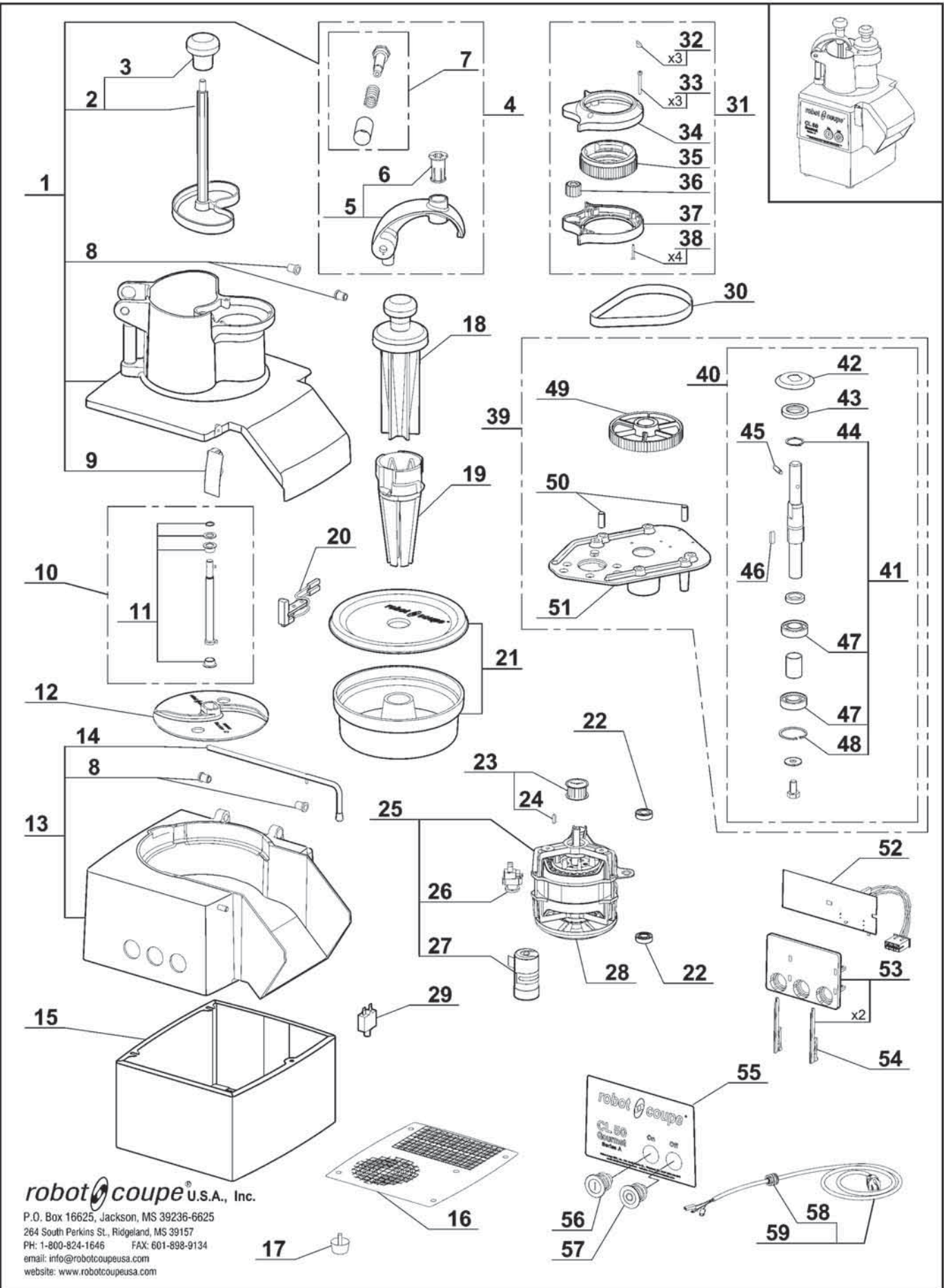

robot coupe® U.S.A., Inc.

P.O. Box 16625, Jackson, MS 39236-6625
264 South Perkins St., Ridgeland, MS 39157
PH: 1-800-824-1646 FAX: 601-898-9134
email: info@robotcoupeusa.com
website: www.robotcoupeusa.com

Index	Part / pièce	Description	Designation
1	39 711	COMPLETE FEED LEAD	COUVERCLE COMPLET
2	39 701	VEGETABLE PUSHER ASSEMBLY	ENSEMBLE POUSSOIR
3	117 452	HANDLE PUSHER	POMMEAU
4	39 702	PUSHER GUIDE + AXLE ASSEMBLY	ENSEMBLE GUIDE POUSSOIR + AXE
5	39 703	PUSHER GUIDE ASSEMBLY	ENSEMBLE GUIDE POUSSOIR
6	100 638	PUSHER GUIDING BUSCHING	BAGUE DE GUIDAGE
7	39 704	GUIDE AXLE ASSEMBLY	ENSEMBLE AXE DE CHAPE
8	39 705	SHOULDERED RINGS (QTY=2)	BAGUE EPAULEE (QTE=2)
9	29 501	LATCH ASSEMBLY	ENSEMBLE TAQUET D'ACCROCHAGE
10	39 715	INTERMEDIATE SHAFT ASSEMBLY	ENSEMBLE ARBRE INTERMEDIAIRE
11	39 714	BUSHINGS SET	ENSEMBLE PALIER
12	102 690	SLING PLATE	DISQUE EVACUATEUR
13	39 706	BOWL ASSEMBLY	ENSEMBLE CUVE
14	100 703	HINGE PIN	TIGE DE CHARNIERE
15	117 686	STAINLESS STEEL MOTOR ENCLOSURE	CAPOT INOX
16	118 443	BOTTOM PLATE	PLAQUE DE FOND
17	500 247	FOOT	PIED
18	117 450	PUSHER	POUSSOIR
19	117 467	HOLDING INSERT	INSERT DE MAINTIEN
20	29 451	SAFETY SWITCH ASSEMBLY	ENSEMBLE INTERRUPTEUR DE SECURITE
21	39 716	MINI BOWL ASSEMBLY	ENSEMBLE MINI CUVE
22	600 457	BALL BEARING	ROULEMENT
23	29 530	DRIVING PULLEY ASSEMBLY	ENSEMBLE POULIE MOTRICE
24	502 768	MOTOR SHAFT KEY 4X4X16	CLAVETTE MOTEUR 4X4X16
25	3 115	MOTOR	MOTEUR
26	500 296	MOTOR STARTING RELAY	RELAIS DEMARRAGE MOTEUR
27	603 669	STARTING CAPACITOR	CONDENSATEUR DE DEMARRAGE
28	118 512	FAN	VENTILATEUR
29	118 442	CIRCUIT BREAKER	COUPE CIRCUIT
30	507 341	BELT HTD 450-5MX15	COURROIE HTD 450-5MX15
31	39 712	GEARS BOX ASSEMBLY	ENSEMBLE REDUCTION GOURMET
32	117 469	SCREW CAPS	CACHE VIS
33	39 720	SCREW CHC 4X35 (QTY=3)	VIS CHC 4X35 (QTE=3)
34	117 465	UPPER COVER	CAPOT SUPERIEUR
35	117 468	PINION 72 TEETH	PIGNON 72DT
36	117 476	PINION 18 TEETH	PIGNON 18DT
37	117 466	LOWER ENCLOSURE	CAPOT INFERIEUR
38	39 719	SCREW TF 3X25 (QTY=4)	VIS TF 3X25 (QTE=4)
39	39 707	MOTOR SUPPORT ASSEMBLY	ENSEMBLE SUPPORT TRANSMISSION
40	39 708	TRANSMISSION SHAFT ASSEMBLY	ENSEMBLE AXE RECEPTEUR
41	39 709	BALL BEARINGS ASSEMBLY	ENSEMBLE ROULEMENTS
42	101 547	DEFLECTOR	DEFLECTEUR
43	501 678	SHAFT SEAL 25X42X7	BAGUE ETANCH 25x42x7
44	203 068	C-RING EXT 25	CIRCLIPS EXT 25
45	110 308	DRIVING PIN	GOUILLE ENTRAINEMENT
46	203 015	KEY 6X6X20	CLAVETTE 6X6X20
47	510 217	BALL BEARING 6004 2RS	ROULEMENT 6004 2RS
48	203 206	C-RING INT 42	CIRCLIPS INT 42
49	105 529	DRIVEN PULLEY	POULIE RECEPTRICE
50	510 218	LOCKING PIN (QTY=2)	DOUILLE ELASTIQUE
51	105 531	MOTOR SUPPORT	SUPPORT TRANSMISSION
52	102 481	CONTROL BOARD	CARTE DE COMMANDE
53	29 533	CONTROL BOARD SUPPORT ASSEMBLY	ENSEMBLE SUPPORT PLATINE
54	117 703	CONTROL BOARD FIXING KEY	CLAVETTE FIXATION PLATINE
55	403 987	FRONT BOARD	PLAQUE FRONTALE
56	502 170	GREEN KNOB I	BOUTON VERT I
57	502 169	RED KNOB	BOUTON ROUGE
58	507 343	STRAIN RELIEF	PRESSE ETOUPE
59	507 027	POWER CORD	CABLE D'ALIMENTATION

CL 50 Series E - CL 50 Ultra Series E - CL 50 Gourmet Series A

ELECTRIC DIAGRAM

120V-60Hz Single phase
SCHEMA CONEXIONES
SCHEMA ELECTRIQUE

Serial # : CL 50 Series E: from 450XXXXX 03 B - MM
 Serial # : CL 50 Ultra Series E: from 452XXXXX 03 B - MM
 Serial # : CL 50 Gourmet Series A: from 456XXXXX 03 B - MM

	English	Espanol	Français
C	Connector	Connecteur	Connecteur
CD	Starting capacitor	Condensador d'arranque	Condensateur de démarrage
DT	Circuit-breaker 15 A	Disyuntor 15 A	Coupe-circuit 15 A
EA	Starting phase	Fase auxiliar	Phase auxiliaire
EP	Main phase	Fase principal	Phase principale
ISC	Lid safety switch	Interruptor de seguridad tapa	Interrupteur sécurité Couvercle
ISP	Pusher safety switch	Interruptor de seguridad boton	Interrupteur sécurité Pousoir
KD	Starting relay	Rele d'arranque	Relais de démarrage
MO	Single phase Motor	Motor monofasico	Moteur monophasé
PCB	Control Board # 102481	Platina Réf 102481	Carte de commande Réf 102481
SAR	Off switch	Boton pulsador de parada	Bouton poussoir arrêt
SMA	On switch	Boton pulsador d'arranque	Bouton poussoir marche
⊖	Motor thermal protector	Protector termico del motor	Protecteur thermique moteur

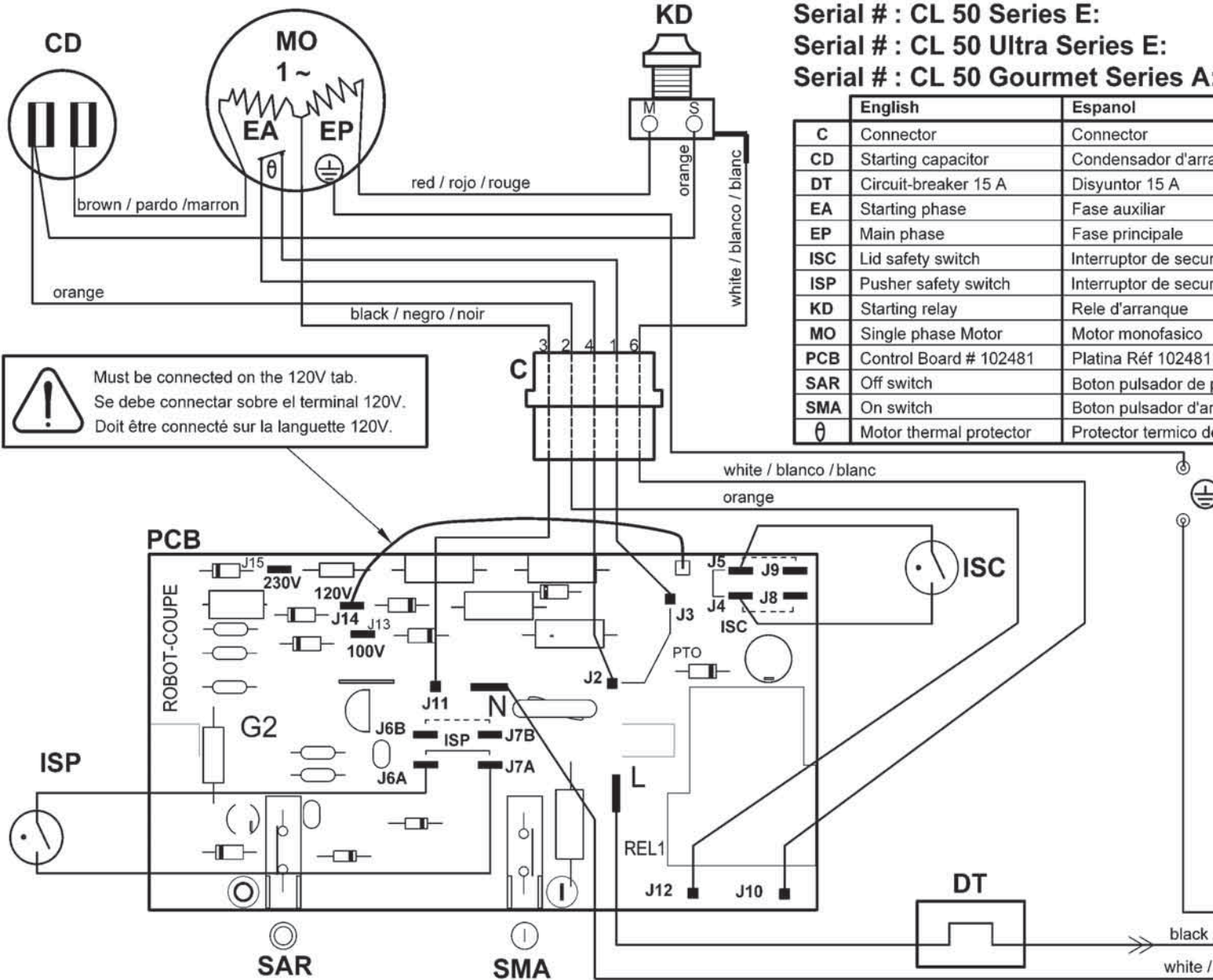

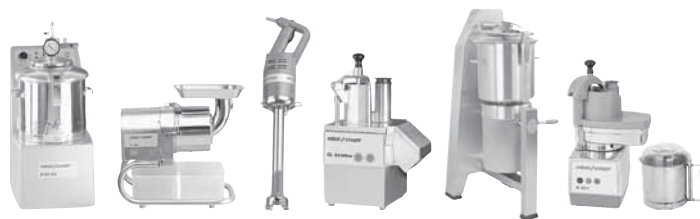

robot coupe[®]

P.O. Box 16625, Jackson, MS 39236-6625

264 South Perkins St., Ridgeland, MS 39157

e-mail: robocoup@misnet.com

website: www.robotcoupeusa.com

Phone : 1-800-824-1646