

# SINGLE-LOAD FRONT-LOAD DRYERS

MDE/MDG28PRTGW, MDG28PRTKW

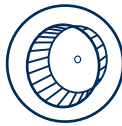

## TURBOVENT® SYSTEM

- Enables installation in long or complicated venting environments
- Helps improve component life



- High airflow helps reduce drying times



## MICROPROCESSOR CONTROLS

- Provide flexibility to price both base cycles and cycle modifiers to help maximize earnings

- Built-in diagnostics assist with quick identification of issues



- Easy-to-read Time Remaining Display keeps users informed



- One-touch cycle selection allows end users to easily choose their preferred dry cycle



## LARGE CAPACITY

- 6.7 cu. ft. capacity dryer helps allow for large loads to be dried efficiently and effectively

- 10.5 kg rated capacity

- Delivers an optimal drying experience for users and helps maximize productivity



- Large reversible door – provides unhindered access while loading and unloading



## BUILT TO LAST

- Porcelain enamel top – a durable finish that stands up to the demands of high traffic

- Blower Guard – protects components to reduce service calls

- Four-Roller Suspension – provides dependable operation and longer life



CARD READY AND NON-VEND  
MDE/MDG28PRTGW, MDG28PRTKW

**AMERICA**  
AN AMERICAN COMPANY FOR OVER 100 YEARS

See [www.bluebadger.co.uk](http://www.bluebadger.co.uk) for warranty details.



End user benefits

**VISIT [BLUEBADGER.CO.UK](http://BLUEBADGER.CO.UK) FOR MORE INFORMATION.**

®/™ © 2023 Maytag. All rights reserved.  
MY220174 05/23

# SINGLE-LOAD FRONT-LOAD DRYERS

## MDE/MDG28PRTGW, MDG28PRTKW



### SIDE VIEW

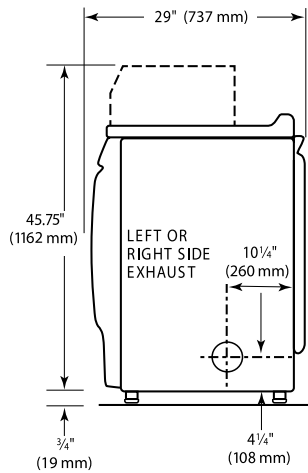

### BACK VIEW

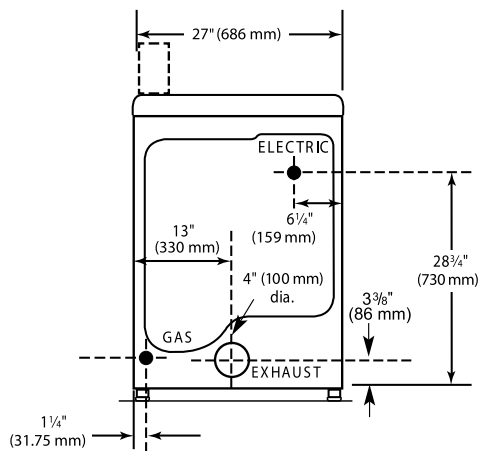

#### MAXIMUM EXHAUST DUCT LENGTH PER NUMBER OF TURNS

Number Of 90° Turns	Rigid Metal Vent	
	Box Hood and Louvered Style	Angled Hood Style
0	39.6 m (130 ft.)	39.3 m (129 ft.)
1	38.1 m (125 ft.)	36.3 m (119 ft.)
2	35.1 m (115 ft.)	33.2 m (109 ft.)
3	32.3 m (106 ft.)	30.5 m (100 ft.)
4	29.9 m (98 ft.)	28.0 m (92 ft.)



\*Includes height of metercase.  
 \*\*Use 4" (102 mm) diameter rigid aluminum or galvanized steel duct. Never use plastic, non-metal or combustible duct.  
 See specific instructions for proper installation. Because of continuous product improvement, Maytag reserves the right to change specifications without notice.  
 Export model ships without coin-drop mechanism.

MODELS	MDE28PRTGW	MDG28PRTGW	MDG28PRTKW
<b>PAYMENT CONFIGURATION</b>	Card Ready & Non-Vend		
<b>FUEL TYPE</b>	Electric	Gas	Gas
<b>CAPACITY</b>			
Cylinder Volume – cu. ft. (liters)	6.7 (190)	6.7 (190)	6.7 (190)
Cylinder Diameter – in. (mm)	26.26 (667)	26.26 (667)	26.26 (667)
Cylinder Depth – in. (mm)	20.39 (518)	20.39 (518)	20.39 (518)
IEC Capacity – lb. (kg)	23.2 (10.5)	23.2 (10.5)	23.2 (10.5)
<b>DIMENSIONS</b>			
Width – mm	686	686	686
Depth – mm	737	737	737
Height – mm	961*	961*	961*
Door Opening – in. (mm)	18.25 (464)	18.25 (464)	18.25 (464)
Exhaust Duct Diameter – in. (mm)	4 (102)**	4 (102)**	4 (102)**
<b>CRATED DIMENSIONS</b>			
Crated Width – in. (mm)	29.06 (738.12)	29.06 (738.12)	29.06 (738.12)
Crated Depth – in. (mm)	30.5 (775)	30.5 (775)	30.5 (775)
Crated Height – in. (mm)	45.63 (1159)	45.63 (1159)	45.63 (1159)
<b>APPROXIMATE WEIGHT</b>			
Uncrated – lb. (kg)	147 (67)	150 (68)	150 (68)
Crated – lb. (kg)	160 (73)	163 (74)	163 (74)
<b>ELECTRICAL REQUIREMENTS</b>			
Voltage	240V	240V	240V
Frequency	50Hz	50Hz	60Hz
Breaker/Fuse – Amps	30	15	15
Airflow – CFM (CMM)	215 (6.1)	230 (6.5)	230 (6.5)
Electric Heating Element (watts)	4,600	N/A	N/A
Gas Rating – BTU/hr (kcal/hr)	N/A	20,000 (5,040)	20,000 (5,040)
Gas Inlet Size – in.	N/A	3/8 N.P.T.	3/8 N.P.T.
Motor Size – HP (kW)	1/3 (.25)	1/3 (.25)	1/3 (.25)