



VEGETABLE PREPARATION MACHINE CA-21 230/50/1 UK

Compact, 1-speed vegetable slicer.



1050942



- ✓ Combination of safety systems: head, cover, power switch.
- ✓ Complete error warning system.
- ✓ Appliance certified by NSF International (regulations on hygiene, cleaning and materials suitable for contact with foods).
- ✓ 100% tested.

INCLUDES

- ✓ 1-speed motor block.
- ✓ Vegetable slicer attachment.
- ✓ Gravity product expulsion ramp.
- ✓ Ejection disc.

OPTIONAL

- Cutter bowl.
- Hub with toothed blades.
- Hub with smooth blades.
- Hub with perforated blades.

ACCESSORIES

- Cutter bowl
- FCS slicing discs
- FCOS rippled slicing disc
- FMS dicing grid
- FFS chipping grid
- FCES julienne discs
- SHS shredding & grating discs
- Hubs with blades

SALES DESCRIPTION

Compact ACTIVE line. 1-speed motor block + vegetable slicer attachment.

A perfect cut

- ✓ High precision settings and comprehensive cutter and disc design aimed at obtaining a perfect cut.
- ✓ Gravity product expulsion ramp allow to reconstruct the sliced product for storing or presentation purpose. (Watch video)
- ✓ Ejection disc included for the products that require its use.
- ✓ Can be fitted with a wide range of discs and grids of the highest cutting quality.
- ✓ Combining these accessories together to obtain more than 35 different types of cuts and grating grades.
Possibility of extending its functionality by adding the cutter bowl with blades.

Built to last

- ✓ Sturdy construction in food-grade best quality materials.
- ✓ High power asynchronous motor.

Maximum comfort for the user

- ✓ Ergonomic design: product sliced in one single movement.
- ✓ Lateral product output: requires less space on the worktop and guides the product, avoiding splashes.
- ✓ Adjustable product ejection direction to adapt to the workflow in the preparation area.
- ✓ Recessed cored relief allows for any position in the kitchen, side walls, back wall, light and compact, this machine can fit.
- ✓ The electronic command panel is very intuitive.

Maintenance, safety, hygiene

- ✓ Lever and lid easily removable for cleaning purposes.
- ✓ Stainless steel, dishwasher-safe discs. The removable blades allow for an even more thorough and efficient cleaning.

SPECIFICATIONS

Hourly production: 50 kg - 350 kg

Inlet opening: 89 cm²

Disc diameter: 180 mm

Motor speed: 1500 rpm

Loading

Total loading: 800 W

Electrical supply: 230 V / 50 Hz / 1~ (7 A)

Noise level (1m.): <70 dB(A)

Background noise: 32 dB(A)

External dimensions (W x D x H)

Width: 378 mm

Depth: 309 mm

Height: 533 mm

Net weight: 15.2 kg

Crated dimensions

382 x 563 x 480 mm

Volume Packed: 0.8 m³

Gross weight: 19.5 kg

DYNAMIC PREPARATION
COMMERCIAL VEGETABLE PREPARATION MACHINES

product sheet
updated 27/05/2024





VEGETABLE PREPARATION MACHINE CA-21 230/50/1 UK

Compact, 1-speed vegetable slicer.



1050942

DYNAMIC PREPARATION
COMMERCIAL VEGETABLE PREPARATION MACHINES

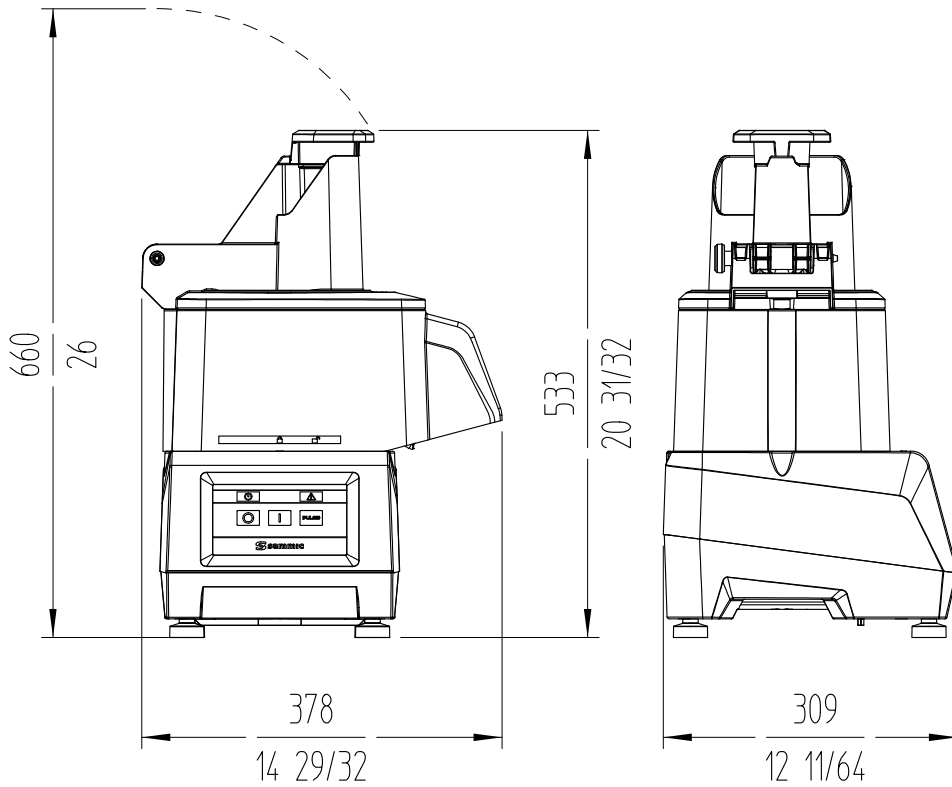

www.sammic.co.uk
 Food Service Equipment Manufacturer
 Unit 2, Trevanah Road
 Troon Industrial Park
 LE4 9LS - Leicester
 uksales@sammic.com
 Tel.: +44 0116 246 1900



Project	Date
Item	Qty
Approved	

product sheet
updated 27/05/2024