

Other models in this range:
 C 0522 - C 0530 - C 0630
 C 0830 - C 1030 - C 1448
 C 1848 - C 2148

Prodigy® Cube Ice Machines up to 137 kg



Features

Prodigy® cubers use **significantly less energy and water** than other cube ice machines, exceeding energy efficiency regulations.

AutoAlert™ indicator lights constantly communicate about operating status and actually signal your staff when it's time to descale, sanitize, and more.

The patented **WaterSense adaptive purge control** delivers maximum reliability by reducing scale buildup for a longer time between cleanings.

Preventative maintenance is simpler than ever with easily-removed panels allowing clear access to internal components and a diagnostic code display insuring the right fix the first time. Reusable air filter is easily removable from the outside.

All external panel components are crafted for **optimal aesthetic appeal** through superior fit and finish.

An optional **advanced feature Smart-Board™** provides additional operational data that can be displayed on-screen or transmitted remotely, resulting in early alert and fast diagnosis of operating issues.

An optional **Vari-Smart™ ultrasonic ice level control** sensor allows you flexibility to program ice levels, for up to 7 days, keeping just the right amount of freshly made ice in the bin.

Matching Bins

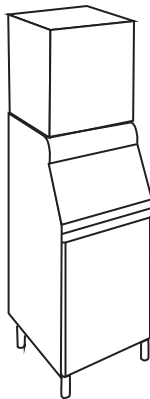

SB 193
 SB 322

Other options available

Technologies



			21°C : 10°C 32°C : 21°C		
			[kg]	[lb]	No. *
C 0322 MA			137	301	13700
C 0322 SA			137	301	27400

*Estimate number of cubes.

[V/Hz/ph]

 220-240/50/1

R404a

[WxDxH mm]

 559 x 610 x 584

 [WxDxH inches]

 22" x 24" x 23"

This product qualifies for the following listings:



5 g

 Small Cube

 22 x 22 x 9.5 mm

 7/8" x 7/8" x 3/8"

10 g

 Medium Cube

 22 x 22 x 22 mm

 7/8" x 7/8" x 7/8"

2 Years Warranty

Subject to certain limitations and exclusions

Certified ISO 9001:2000

www.scotsman-ice.it
www.scotsman-ice.com

Other models in this range:
 C 0522 - C 0530 - C 0630
 C 0830 - C 1030 - C 1448
 C 1848 - C 2148

Prodigy® Cube Ice Machines up to 137 kg

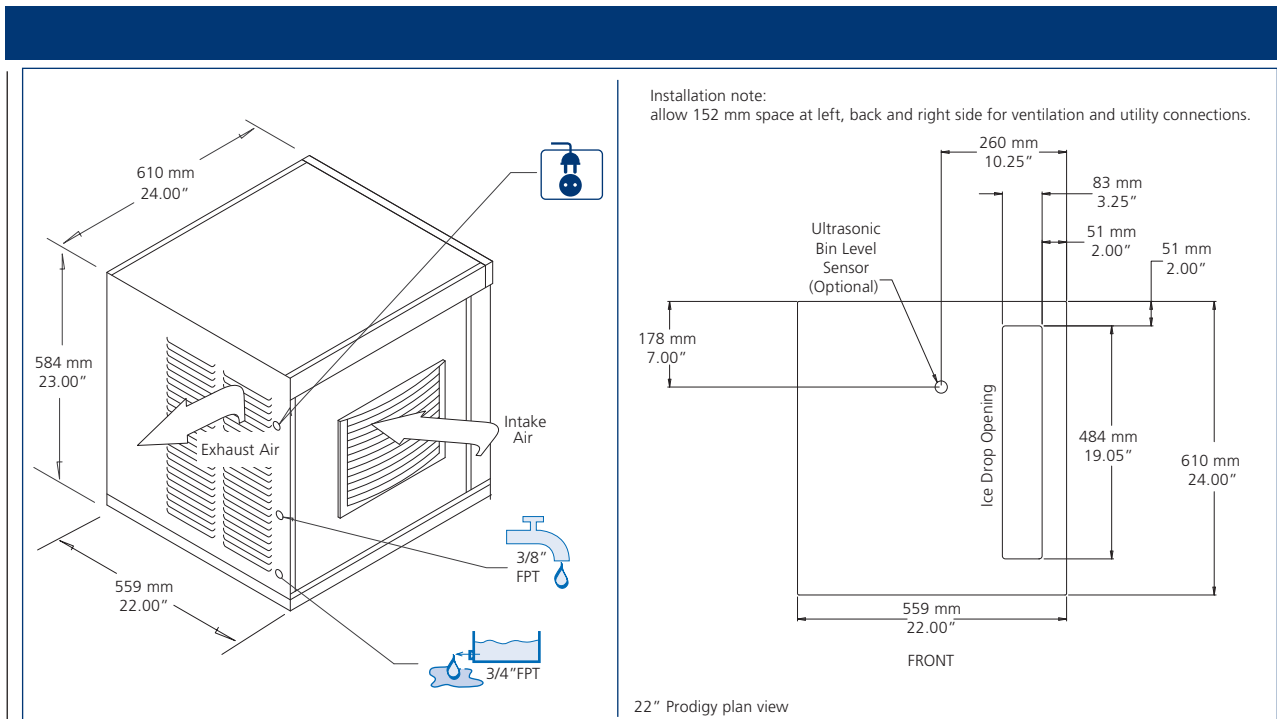

Minimum		Maximum
10°C (50°F)		40°C (100°F)
5°C (40°F)		35°C (95°F)
-10%		+10%
1 BAR 14 psi		5 BAR 70 psi

	[C°] [F°]	[Btu/h] [W]	[Ømm²]	[W]	FUSE	100 kg [kWh] - 100 kg	[l/h]	32°C 90°F 21°C 70°F	[kg] [lbs]	[kg] [lbs]
C 0322 MA		5200 1522	3 x 1,5	890	15 A	11	5,5	1,5	59 130	66 146
C 0322 SA		5200 1522	3 x 1,5	890	15 A	11	5,5	1,5	59 130	66 146

IMPORTANT NOTICE:
 Models and specifications are subject to change without notice.
 This spec sheet is meant for commercial purpose only.
 For technical documentation please refer to our service manuals.

www.scotsman-ice.it
www.scotsman-ice.com

Scotsman®
 Ice Systems

Milano Madrid Chicago Dubai Singapore Shanghai Johannesburg