

ecostore

2 Door Digital Stainless Steel Freezer, 1430lt (-22/-15) R290 - UK Plug

ITEM # _____

MODEL # _____

NAME # _____

SIS # _____

AIA # _____

725292 (RE4142FFCG)

 2-door Freezer
 1430lt, -22-15°C, digital,
 stainless steel, R290 - UK
 plug

Short Form Specification

Item No.

Two full doors freezer with internal and external structure in 430 AISI stainless steel; external back panel in galvanized steel and bottom panel in anti-corrosive material. Digital control with cabinet temperature display and setting and manual activation of defrost cycle. Fully compliant HACCP digital controls include visible alarms. Optimized back to front forced air flow provides even temperature distribution and fast cooling in any conditions. Fitted with 75 mm-thick cyclopentane insulating foam. Door features lock and door microswitch to switch off the fan when the door is opened. Hidden evaporator to guarantee higher storage capacity and less corrosion problems. Built-in refrigeration unit; ventilated operation; automatic defrost and evaporation of defrost water. Operating temperature: -22/-15 ° C. CFC and HCFC free. R290 gas in refrigeration circuit. Integrated RS485 port to facilitate connection to a remote computer and integrated HACCP systems. Mounted on wheels and equipped with UK plug.

Main Features

- Large storage area suitable to contain 2/1 GN grids or shelves on anti-tilt runners.
- Optimized back to front forced air flow provide even temperature distribution and fast cooling in any conditions.
- Automatic defrost.
- Internal structure with numerous charging positions available to host grids, ensuring higher net capacity and a greater storage space.
- Cabinet fitted with up to 75 mm thickness of cyclopentane insulation for best insulating performance with 100% environmental protection (thermal conductivity: 0,020 W/m*K).
- 60 mm-thick insulation covering the evaporator can be easily removed with a single operation.
- Rilsan coated grids for improved protection.
- Hidden evaporator thus guaranteeing higher storage capacity and less corrosion problems.
- Connectivity ready for real time access to connected appliances from remote and data monitoring (requires optional accessory).
- Right hinged full door.
- Integrated RS485 port to facilitate connection to a remote computer and integrated HACCP systems.
- Tropicalized unit.
- Easy serviceability thanks to the intuitive control panel with access via app.
- Large digital white-digit display with cabinet temperature display and setting, activation of turbo frost cycle (to rapidly cool warm loads) and possibility to activate manually the defrost cycle.
- Freezer model has operating temperatures that can be adjusted from -22 to -15 °C.

Construction

- Stainless steel runners and supports easily disassembled.
- Anti-corrosion bottom avoids any damage that may be caused to the cabinet by aggressive detergents employed to clean the floors.
- Lockable door.
- Doors are self-closing and can be fully opened up to 180°.
- Mounted on wheels.
- The rounded internal corners, the easily removable runners and grids allow for ease of cleaning and high hygiene standards.
- Delivered with UK plug.
- AISI 430 stainless steel internal structure and external panels.
- Easy access to the main components for maintenance.

Sustainability

- Door switch stops the fan when door is opened to avoid cold air exiting the cell, thus saving energy.
- Removable triple-chamber balloon magnetic



APPROVAL: _____

gasket to improve insulation and reduce energy consumption and ease of cleaning.

- Automatic evaporation of the defrosting water by hot gas on the top for energy saving.
- CFC and HCFC free, highly ecological refrigerant type: R290 (ecological gas in foam: cyclopentane). Hydrocarbon refrigerant gas R290 for the lowest environmental impact (GWP=3), to reduce green house and ozone depletion effects.

Included Accessories

- 6 of 2/1GN grey rilsan grid with 2 runners PNC 881020
- 1 of Kit of 4 small swivelling wheels, 2 with brake, diam 50 mm, not for remote models PNC 881035

Optional Accessories

- 2 stainless steel runners for refrigerated cabinets - (Marine) PNC 880242
- Spacer for 670 lt and 1430 lt refrigerated cabinets PNC 880248
- Kit 20 pair runners and tray supports to fit pastry trays (400x600mm) PNC 880333
- Kit of 6 swivelling wheels, 2 with brake, diam 50 mm PNC 880340
- Kit remote alarm PNC 880570
- Ethernet connectivity kit IJF for Refrigeration PNC 880685
- 1/1GN plastic container with false bottom PNC 880705
- 2/1GN grey rilsan grid PNC 881004
- 2/1GN aisi 304 stainless steel grid PNC 881016
- 2/1GN 304 AISI stainless steel grid with 2 runners PNC 881018
- 2/1GN grey rilsan grid with 2 runners PNC 881020
- Pedal opening for 1430lt refrigerator PNC 881033
- Kit of 4 small swivelling wheels, 2 with brake, diam 50 mm, not for remote models PNC 881035
- 2/1GN pvc container with lid and 2 runners PNC 881039
- 2/1GN perforated shelf PNC 881042
- 1/1GN rilsan steel wire basket h=150mm PNC 881043
- 3 grey rilsan central grids for 1430lt (not for glass door) PNC 881044
- 2/1GN grey rilsan basket+2 runners h=150mm PNC 881047
- 5 swivelling wheels (2 with brake), diam 125mm, for 1430 lt refrigerators, NOT for remote models PNC 881294
- IOT module for refrigerated cabinets and counters PNC 881298
- POE switch PNC 922432

Front

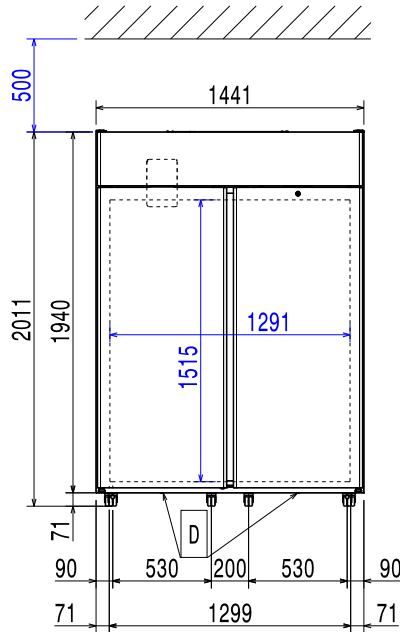

Side

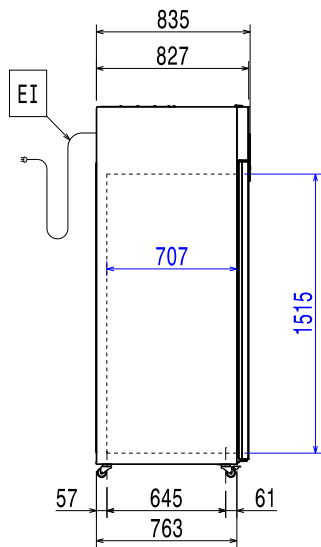

EI = Electrical inlet (power)

Top

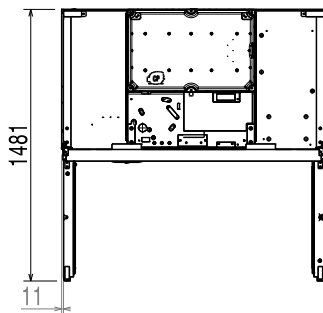

Electric

Supply voltage:	725292 (RE4142FFCG)	220-240 V/1 ph/50 Hz
Electrical power max.:		0.8 kW

Key Information:

Gross capacity:	1430 lt
Net Volume:	1135 lt
Door hinges:	1 Left+1 Right
External dimensions, Width:	1441 mm
External dimensions, Depth:	835 mm
External dimensions, Depth with Doors Open:	1480 mm
External dimensions, Height:	2010 mm
Number and type of doors:	2 Full
Number and type of grids (included):	6 - GN 2/1
Type of external material:	Stainless Steel
Type of internal material:	Stainless Steel
Internal panels material:	Stainless Steel
Number of positions & pitch:	44; 30 mm

Refrigeration Data

Control type:	Digital
Refrigeration power at evaporation temperature:	-30 °C
Operating temperature min.:	-22 °C
Operating temperature max.:	-15 °C
Operating mode:	Ventilated

Product Information (EU Regulation 2015/1094)

Type of model (EU Reg. 2015/1094):	vertical frozen
------------------------------------	-----------------

ISO Certificates

ISO Standards:	ISO 9001; ISO 14001; ISO 45001; ISO 50001
----------------	---

Sustainability

Energy Class (EU Reg. 2015/1094):	D
Yearly and daily energy consumption (EU Reg. 2015/1094):	4314kWh/year - 12kWh/24h
Climate class (EU Reg. 2015/1094):	Heavy Duty (5)
Energy Efficiency Index-EEI (EU Reg. 2015/1094):	61,05
Refrigerant type:	R290
GWP Index:	3
Refrigeration power:	833 W



Electrolux
PROFESSIONAL

ecostore
2 Door Digital Stainless Steel Freezer, 1430lt (-22/-15) R290 - UK Plug

EU energy labelling from 1st July 2016

The European energy labelling scheme for professional refrigerators and freezers is based on requirements setting Minimum Energy Performance standards for commercial refrigeration cabinets sold within the EU.

These requirements are designed to drive energy efficiency and environmentally friendly approach for professionals. The European energy labelling scheme will apply to all manufacturers and importers who sell and market products within the EU and it is mandatory across Europe. Important: all products which consume energy above the minimum level will not be able to be sold within the EU from 1 July 2016.

SI 2020 No. 1528.

Important: all products which consume energy above the minimum level will not be able to be sold within the EU from 1 July 2016.

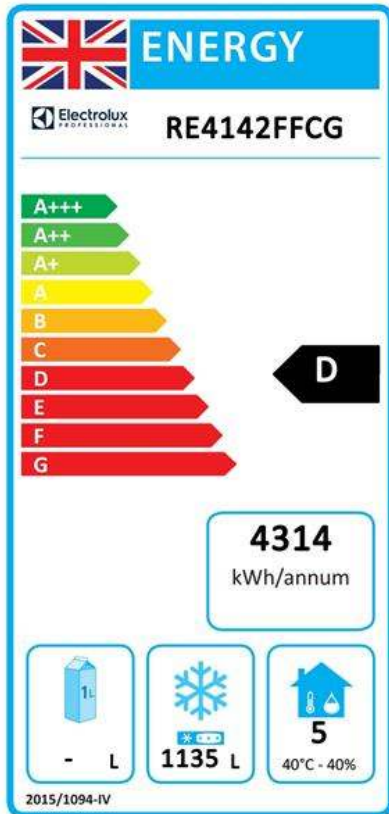
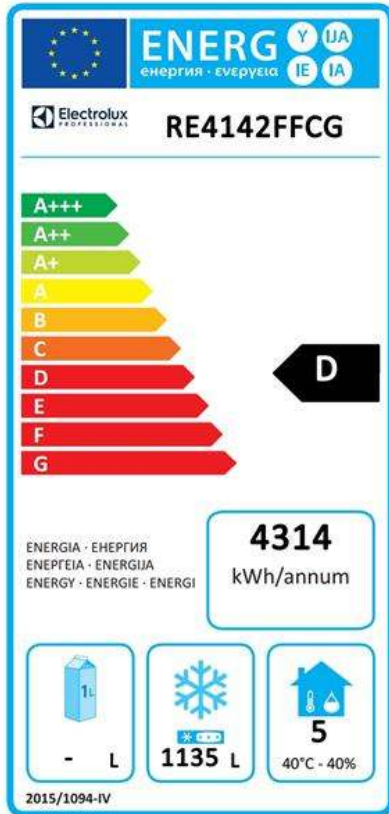

ecostore
2 Door Digital Stainless Steel Freezer, 1430lt (-22/-15) R290 - UK Plug

The company reserves the right to make modifications to the products without prior notice. All information correct at time of printing.

2024.09.13