

Dough Mixers

53 liter Spiral Dough Kneader, 2 Speeds

ITEM # _____

MODEL # _____

NAME # _____

SIS # _____

AIA # _____

602280 (ESK53L)

 53 lt spiral Dough Kneader,
 2 speed (tool speed 80/160
 rpm), on wheels

Short Form Specification

Item No. _____

2 speed spiral dough kneader on wheels for pizzerias, bakeries and pastries. Ingredients are kneaded with a stainless steel spiral mixer arm synchronised with bowl rotation (motorized not removable bowl). Body is in painted steel, the 53 lt capacity bowl, spiral mixer arm and dough breaker pin are in stainless steel. The safety screen allows ingredients to be added without stopping. Equipped with low voltage control panel with on/off switch, speed selection and timer (up to 30 min) or continuous mode. Safety device to stop the machine when the protection screen is opened. Tool speed: 80 and 160 rpm; bowl speed: 10 and 20 rpm. Maximum dough capacity: 42 kg per cycle (60% hydration).

Main Features

- Spiral dough kneader with motorized bowl (not removable) and fixed head.
- Ideal for kneading pizza dough, bread or similar dough.
- Two speed kneading for faster cycles (tool speed: 80 and 160 rpm; bowl speed: 10 and 20 rpm).
- Stainless steel (AISI304) squared dough breaker bar for fast and even kneading results
- Minimum kneading capacity: 23 kg per cycle, with 60% hydration.
- Maximum kneading capacity 42 kg per cycle (max. flour 26.3 kg/cycle), with 60% hydration.
- Maximum flour per cycle: 26 kg/cycle (for dough at 60% hydration).
- Transparent protective screen to reduce flour dust release in the work area during kneading (EU EN453:2014) and to prevent dough contaminations.
- Safety device stops the appliance if the cover is opened.
- Equipped with 4 wheels, of which 2 with brakes, allowing to easily move the appliance for storage or cleaning.
- The appliance fits under standard kitchen worktops (see installation drawing).

Construction

- Constructed in painted steel.
- AISI304 stainless steel bowl, spiral hook and dough breaker bar.
- Control panel with on/off switch, speed selection and timer.
- Analogic timer up to 30 minutes or continuous mode.
- IP54 protected control panel.
- IP23 for the appliance overall.

APPROVAL: _____

Side

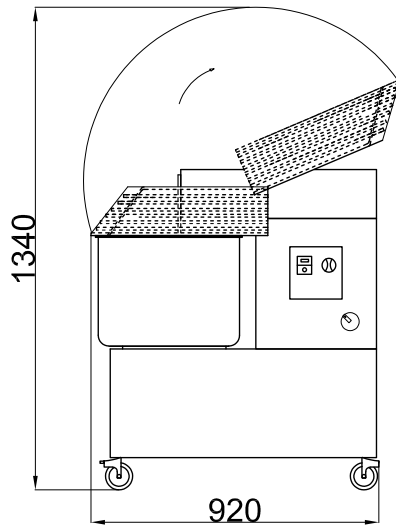

Front

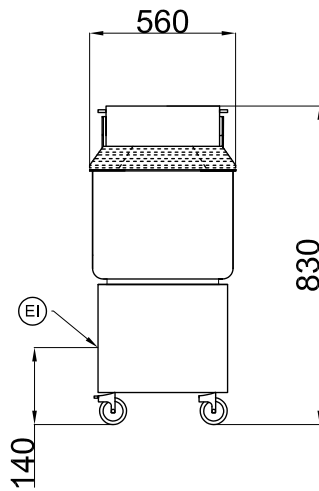

EI = Electrical inlet (power)

Top

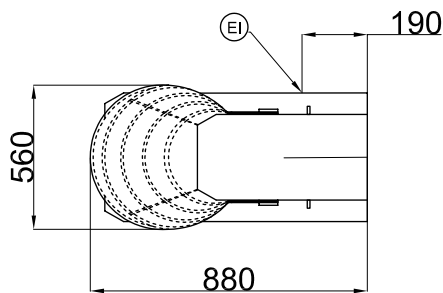

Electric

Supply voltage:

602280 (ESK53L) 380-415V/3 ph/50 Hz

Total Watts:

2.2 kW

Capacity:

Maximum kneading (60% hydration):

42 kg/Cycle

Key Information:

External dimensions, Width: 560 mm

External dimensions, Depth: 880 mm

External dimensions, Height: 830 mm

Shipping weight: 117 kg

Bowl capacity: 53 lt